

Instruction Manual

CertoClav Vacuum Pro Series

CV-8-V-Pro

CV-12-V-Pro

CV-18-V-Pro

CV-22-V-Pro



Distributed by:

Lab Unlimited
CARL STUART GROUP

Tallaght Business Park
 Whitestown, Dublin 24,
 Ireland
 D24 RFK3

Tel: (01) 4523432
 Fax: (01) 4523967
 E-mail: info@labunlimited.com
 Web: www.labunlimited.com

Quatro House, Frimley Road,
 Camberley,
 United Kingdom
 GU16 7ER

Tel: 08452 30 40 30
 Fax: 08452 30 50 30
 E-mail: info@labunlimited.co.uk
 Web: www.labunlimited.co.uk

Contents

1	<i>Using range of this instruction manual</i>	6
2	<i>Explanation of symbols</i>	7
3	<i>Safety warnings - Please read carefully</i>	8
4	<i>Forbidden substances for autoclaving</i>	9
5	<i>Introduction</i>	9
5.1	Using range of the autoclave	10
5.2	Technical data	10
5.3	Requirements of transportation and storage	10
5.4	Dimensions and weight	10
6	<i>Scope of delivery</i>	11
7	<i>Installation and commissioning</i>	11
7.1	Unpacking the autoclave	11
7.2	Installation of the autoclave	11
7.3	Installation of optional accessories	13
7.3.1	Connection of protocol printer.....	13
7.3.2	Connection of barcode scanner	14
7.3.3	Connection of label printer	14
7.3.4	Connection of R/O System	14
7.4	Atmospheric pressure adjustment	14
7.5	Validation and calibration	15
8	<i>List of available sterilization programs</i>	15
9	<i>Basic operation</i>	17
9.1	Turning on the autoclave	17
9.2	Turning off the autoclave	17
9.3	Turning the autoclave into stand-by	17
10	<i>Instructions for daily use</i>	18
10.1	Preparation before using	18
10.2	Refilling water	18
10.3	Steps to start a cycle	19
10.3.1	Selection of a program.....	19
10.3.2	CertoTrace – Decontamination process documentation	19
10.3.3	Step-by-step guide	20
10.3.4	Load the autoclave	20
10.3.5	Close the autoclaves door	20
10.3.6	Material testing mode – Automatic repeating start	21
10.3.7	Autoclave status screen	21
10.4	Unload the autoclave	21

- 10.5 Drain water from waste water tank 22**
- 10.6 CertoCloud software for PC 23**
- 11 Autoclave menu overview 24**
- 11.1 Login menu 24**
- 11.2 Information menu 26**
 - 11.2.1 Tutorial videos..... 26
 - 11.2.2 How to send an e-mail to CertoSupport 26
 - 11.2.3 TeamViewer remote support via screen sharing 27
- 11.3 Sterilization menu 28**
- 11.4 Logging menu 28**
 - 11.4.1 View protocols 28
 - 11.4.2 Print protocols..... 28
 - 11.4.3 Print tracing label 29
 - 11.4.4 Tracing of labeled items 29
- 11.5 Monitor menu 30**
- 12 Autoclave settings overview 31**
- 12.1 User settings 31**
- 12.2 Network settings..... 31**
 - 12.2.1 Connect to WIFI network 31
 - 12.2.2 Connect to LAN 32
 - 12.2.3 Enable or disable online mode..... 32
- 12.3 Sterilization settings..... 33**
 - 12.3.1 Record a running cycle via USB 33
 - 12.3.2 Export all protocols to USB flash drive 33
 - 12.3.3 Export all protocols to SD-Card 33
 - 12.3.4 Export all protocols to CertoCloud online storage 34
 - 12.3.5 Change user defined program..... 34
 - 12.3.6 Preheating ON/OFF 35
 - 12.3.7 Keep autoclave at operation temperature ON/OFF..... 35
 - 12.3.8 Step by Step assistant 35
 - 12.3.9 Material testing mode – Automatic repeating start 36
 - 12.3.10 CertoTrace - Decontamination process documentation 36
 - 12.3.11 Label printer designer 36
- 12.4 System settings 37**
 - 12.4.1 Change date and time 37
 - 12.4.2 Check for updates over internet 37
 - 12.4.3 Install updates from USB flash drive 37
 - 12.4.4 Install updates from external SD card 38
 - 12.4.5 Factory reset 38
- 12.5 Language settings 39**
- 12.6 SMS and e-mail notification settings 39**
- 12.7 Sensor calibration settings 40**
- 13 Troubleshooting 41**
- 14 Maintenance 44**
- 14.1 Door tightness adjustment 44**

14.2 Cleaning of the seal ring **45**

14.3 Replacement of the seal ring **45**

14.4 Regular check of the safety valve **45**

15 *Transportation and storage* **46**

15.1 Preparation..... **46**

15.2 Drainage **46**

15.3 Terms of transportation **46**

15.4 Terms of storage **46**

16 *Warranty* **46**

17 *Appendixes* **47**

17.1 Appendix 1: Structure diagram **47**

17.2 Appendix 2: Circuit diagram..... **48**

17.3 Appendix 3: EMC..... **49**

CE DECLARATION OF CONFORMITY

PRODUCT: CERTOCLAV AUTOCLAV

This is to certify, that the **CERTOCLAV** Product Ranges CV-8-Vac-Pro, CV-12-Vac-Pro, CV-18-Vac-Pro and CV-22-Vac-Pro comply with the following regulations of the European Community:

2014/35/EU Low Voltage Directive

Associated Standards:

EN 61010-2-040:2005 Part 2: Particular requirements for sterilizers and washer-disinfectors used to treat medical material.

EN 61010-1:2001 Safety requirements for electrical equipment for measurements, control and laboratory use – Part 1: General requirements

The CertoClav pressure equipment is constructed according Low Voltage Directive.

2014/30/EU Electromagnetic compatibility

Associated Standards:

EN 61326-1:2013 Electrical Equipment for measurements, control and laboratory use - EMC Requirements- Part 1: General requirements

EN 61000-3-2:2006 + A1:2009 + A2:2009 Electromagnetic Compatibility (EMC) — Part 3- 2: Limits — Limits for harmonic current emissions (equipment input current equal to or less than 16 A per phase)

EN 61000-3-3:2013 Electromagnetic compatibility — Part 3- 3: Limits — Limits for voltage fluctuation and flicker on the public low-voltage system (equipment having an input current equal to or less 16 A per phase) and not subject to conditional connection.

2011/65/EU Restriction of the use of certain hazardous substances (RoHS) Directive

Associated Standards:

EN 50581:2012 Technical documentation for the assessment of electrical and electronic products with respect to the restriction of hazardous substances

Base unit assembled from Ningbo Yinzhou Life Medical Technology Co., LTD in No. 1, Jinghui Road, Hengjie Town, Yinzhou, Ningbo, Zhejiang, China

Manufacturer:

CERTOCLAV Sterilizer GmbH

Georg Grinninger-Str. 37

A-4050 Traun / Austria











Mag. Moritz Gruber
Geschäftsführer

Traun, 29.10.2016















1 Using range of this instruction manual

This instruction manual is for models:

- CV-8-V-Pro
- CV-12-V-Pro
- CV-18-V-Pro
- CV-22-V-Pro

	Please do not operate the device according to other instruction manuals
	This manual is made for CertoClav Vacuum Pro Series autoclaves, which are controlled by CertoTouch User Interface
	Please read the manual carefully before operating the autoclave.
	Please operate the autoclave strictly according to this manual.
	Please keep this manual on a reachable place near the autoclave.
	Please contact your local distributor or CertoClav Support (support@certoclav.com) if there's any problem with the autoclave.
	The person who operate and maintain the autoclave shall be specified and well trained.
	Please appoint specific person to operate and maintain the device. The person must be well trained.

2 Explanation of symbols

	Symbol for "CAUTION!"
	Symbol for "PROTECTIVE CONDUCTOR TERMINAL"
	Symbol for "HOT SURFACE, KEEP AWAY"
	Symbol for "ENVIRONMENTAL PROTECTION – Electrical wastes should not be disposed together with household wastes. If possible, please contact local distributor or government to recycle it."
	Symbol for "MANUFACTURER"
	Symbol for "Communauté européenne"
	Symbol for "DATE OF PRODUCTION"
	Symbol for "SERIAL NUMBER"
	Symbol for "EUROPEAN REPRESENTATIVE"
	Symbol for "THIS SIDE UP"
	Symbol for "KEEP AWAY FROM RAIN"
	Symbol for "DO NOT ROLL"
	Symbol for "STACKING LIMITED 3"
	Symbol for "ROOM TEMPERATURE: 5°C~40°C"
	Symbol for "RELATIVE HUMIDITY: ≤80%"

3 Safety warnings - Please read carefully



Electric shock, fire or equipment damage might happen if you ignore below warnings

1. Please use 3-hole socket, and ensure the socket has been connected well with the ground. Do not put the autoclave on a place that the power are difficult to be cut off.
2. Do not use power with different voltage with that stated in this manual.
3. Do not touch the plug or socket with wet hands.
4. Do not pull, change, over-bend or twist the wires, and do not put heavy things on the wires.
5. Do not put the autoclave on an unstable table.
6. Do not block the door of autoclave, and cover the ventilation holes and radiation holes.
7. Do not put anything on the top of autoclave.
8. If you find any abnormal smell or sound during operation, please cut off the power immediately and contact your local distributor or us.
9. If you do not use the autoclave for a long time, please cut off the power and store the autoclave in a dry and cool place.
10. Plug in only the mobile touchscreen from CertoClav into the serial port on the back. No other devices.
11. Never manipulate the safety devices. Operate only mobile touchscreen and autoclave of the same series.
12. Use only in accordance with this manual. Store the manual in a space accessible to all users.
13. Must not be installed in a space that is subject to the danger of explosions
14. Use only with rated voltage.
15. Only for use in laboratories. Operate only by trained personnel. Do not use in domestic settings.
16. Do not autoclave tightly sealed containers (especially glass bottles) since there is no pressure compensation.
17. Fill only distilled water into the water tank.
18. Please fill bottles always at maximum half full with liquid.
19. If the pressure is released quickly when autoclaving liquids, there is a possibility that the liquid will boil.
20. Do not transport when filled. Do not open with force.
21. This autoclave must only be maintained by CertoClav or authorized retailers. Always use original spare parts.
22. Use original spare parts from manufacturer only.

4 Forbidden substances for autoclaving

Never use the autoclave to sterilize any of the following hazardous materials or substances with alkali content. Sterilization of such objects can cause explosion, corrosion of the working chamber or chamber piping, and deterioration of gaskets.

Explosive substances

Nitroglycol, nitroglycerin, nitrocellulose, and other explosive nitric esters.

Trinitrobenzene, trinitrotoluene, picric acid, and other explosive nitro compounds.

Peracetic acid, methyl ethyl ketone peroxide, benzoyl peroxide, and other organic peroxides.

Ignitable substances

Metallic lithium, potassium, sodium, yellow phosphorous, phosphorus sulfide, and red phosphorus.

Celluloids, calcium carbide (carbide), lime phosphide, and magnesium powder.

Aluminum powder, magnesium powder, and metallic powders other than aluminum powder.

Sodium dithionite (or sodium hydrosulfite).

Oxidizing agents

Potassium chlorate, sodium chlorate, ammonium chlorate, and other chlorates.

Potassium perchlorate, sodium perchlorate, ammonium perchlorate, and other perchlorates.

Potassium peroxide, sodium peroxide, barium peroxide, and other inorganic peroxides.

Potassium nitrate, sodium nitrate, ammonium nitrate, and other nitrates.

Sodium chlorite and other chlorites.

Calcium hypochlorite and other hypochlorites.

Flammable substances

Ethyl ether, gasoline, acetaldehyde, propylene oxide, carbon disulfide, and other substances whose flash points range from -30 to 0°C.

Methanol, ethanol, xylene, benzyl acetate (or amyl acetate), and other substances whose flash points range from 0 to 30°C.

Kerosene, gas oil, turpentine oil, isopentyl alcohol (or isoamyl alcohol), acetic acid, and other substances whose flash points range from 30 to 65°C.

Flammable gas (hydrogen, acetylene, ethylene, methane, ethane, propane, butane, and othersubstances that are gases at a temperature of 60°C at 0.2 bar absolute pressure.)

If liquid with salt water and much salinity of salt agar etc has been spilled in the chamber, remove all water in the chamber and wipe up all water around the lid gasket.

5 Introduction

This autoclave is an automatic vacuum steam sterilizer. The autoclave can perform all kinds of cycles known from class B, class S and class N autoclaves. The autoclave sterilizes liquids in bottles, hollow bodies of type A and B, porous materials, textiles, double wrapped, single wrapped and unpacked solid instruments. In material testing mode, the cycles can be performed fully automatically without user interaction. The autoclave has an 7" touch interface and a digital built in front panel LCD screen. 4 independent temperature sensors, a flexible media temperature sensor, a high precision pressure sensor, vacuum pump made-in-Germany, safety valves, electrical locker, safety switches and two independent microcontrollers ensure safe operation and automatic monitoring of the autoclave. The

autoclave detects errors automatically. If an error occurred, the autoclave cuts off the power automatically and ensures the safety of operator.

5.1 Using range of the autoclave

Sterilization:

This autoclave can be used in laboratory practices for sterilization of liquids, textiles, double wrapped instruments, solid instruments, hollow materials, porous materials and liquids in bottles. The autoclave can perform class B, class S and class N cycles.

Automated material testing:

The autoclave has also been designed to perform material tests for any materials and medical products (Class B, class S and class N cycles). With RO System (Order number 8500499), the autoclave can automatically perform up to 300 cycles without any need of user interaction. The status of the autoclave can be monitored via network. The autoclave alarm system sends notifications via sound, SMS and email.

5.2 Technical data

- Environmental temperature: 5°C~40°C
- Relative humidity: ≤80%
- Atmospheric pressure: >70kPa;
- Voltage: 230VAC, 50Hz, 2500VA
- Maximum working pressure: 0.21~0.23MPa
- Maximum working temperature: 134~137°C
- Life span of the autoclave: 5 years

5.3 Requirements of transportation and storage

- Environmental temperature range: 5~40°C
- Relative humidity: ≤80%
- No corroding gases

5.4 Dimensions and weight

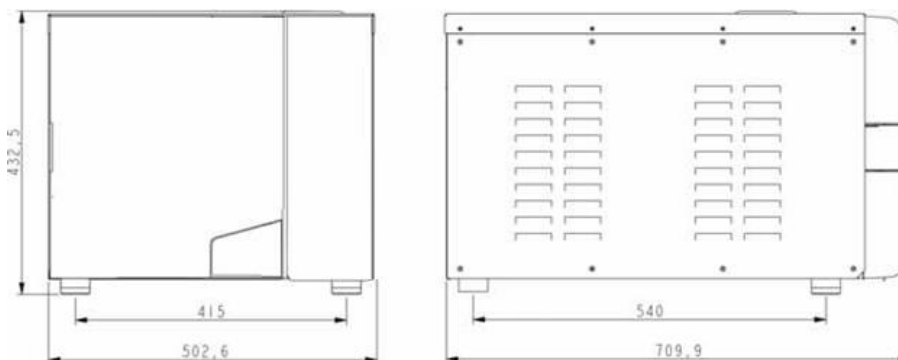

Net weight of the autoclave	
Model	Net weightt
CV-12-C-Pro	47,70 kg
CV-18-V-Pro	50,25 kg
CV-22-V-Pro	53,50 kg

6 Scope of delivery

Please check the product box for the following items

Position	Description	Quantity
1	Quick-connect drain water hose	1
2	Tray set: 1 tray frame, 1 tray holder, 3 trays	1
3	Power cable of autoclave	1
4	User manual	1
5	Touchscreen extension cable	1
6	Power cable for touchscreen	1
7	Stand bracket for touchscreen including 4 screws for mounting	1
8	Touchscreen	1
9	Autoclave	1
10	Guarantee card	1
11	Safety test report	1

7 Installation and commissioning

7.1 Unpacking the autoclave

1. The autoclave is packed by a wooden carton.
2. Use a flat screwdriver to open the cover.
3. Take out the user manual, guarantee card, touchscreen and accessories.
4. The autoclave can be lifted out by 2 persons.



7.2 Installation of the autoclave

1. When installing the autoclave on top of a table, please keep the autoclave at least 10cm away from surroundings. The table must be able to resist at least 65kg weight. Keep the rear side of the autoclave at least 20cm away from the surrounding. It is recommended to install the autoclave in a well-ventilated location. Don't block the radiator of the sterilizer. Keep the table stable & horizontal.

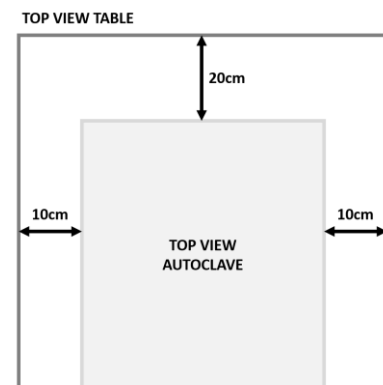

2. Open the autoclave and take out the tray set and accessories out of the chamber to unwrap it.



3. Mount the stand bracket to the touchscreen with 4 screws. The screws are included with the stand bracket.



4. The assembled touchscreen must look like the screen on the following picture.



5. Connect the extension cable with the touchscreen.



6. Plug the power supply into the extension cable.



7. Place the touchscreen only on levelled, stable surfaces. The waterproof industrial touchscreen can be placed on top of the autoclave or next to it.



	Please ensure that the table of installation is strong enough for an autoclave including water and load weight.
--	-----------------------------------------------------------------------------------------------------------------

- 8. Plug in the power cable on the back of the autoclave. Note: Please check if the power input specification on the nameplate of the autoclave is fitting to the power source specification. Ensure proper grounding. Check if the fuses on the rear of the autoclave are switched to upper position. Turn on the autoclave base unit.

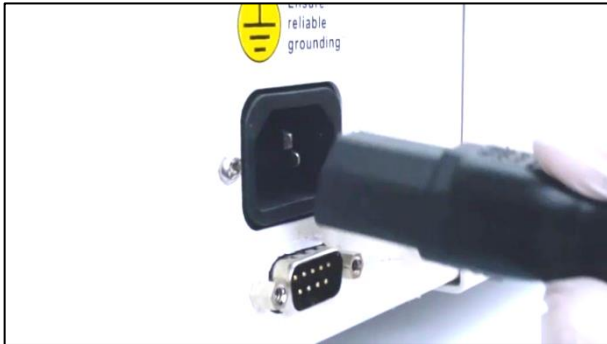

- 9. Connect the RS232 cable “COM 4” with the RS232 port on the back of the autoclave.



- 10. Turn on the touch screen.
- 11. If the login screen appears after a few seconds, the touch screen has been connected correctly.
- 12. If a connection error message appears on the touch screen the touchscreen is not able to connect with the autoclave. Please check if the touch screen has been connected correctly with the “COM 4” cable. If the problem still remains, please perform a factory reset on the touch screen. Navigate to Settings -> Device->Factory Reset and confirm the warning dialog.

7.3 Installation of optional accessories

7.3.1 Connection of protocol printer

Connect the protocol printer with the COM 1 cable of the touchscreen extension cable.	
---------------------------------------------------------------------------------------	--

7.3.2 Connection of barcode scanner

<p>Connect the barcode scanner with the USB-host connector of the touchscreen extension cable.</p>	
----------------------------------------------------------------------------------------------------	-------------------------------------------------------------------------------------

7.3.3 Connection of label printer

<p>Connect the label printer with the COM 2 connector of the touchscreen extension cable.</p>	
-----------------------------------------------------------------------------------------------	-------------------------------------------------------------------------------------

7.3.4 Connection of R/O System

<p>Please read the user manual of the R/O System, how to connect the R/O System with the autoclave</p>	
--------------------------------------------------------------------------------------------------------	--------------------------------------------------------------------------------------

7.4 Atmospheric pressure adjustment

Because every place of installation has a bit different level of atmospheric pressure, the user shall adjust the atmospheric pressure before first use of the autoclave.

Adjust method:

1. Power on the autoclave and touchscreen
2. Open the door of the autoclave
3. Navigate to Settings->Calibration.

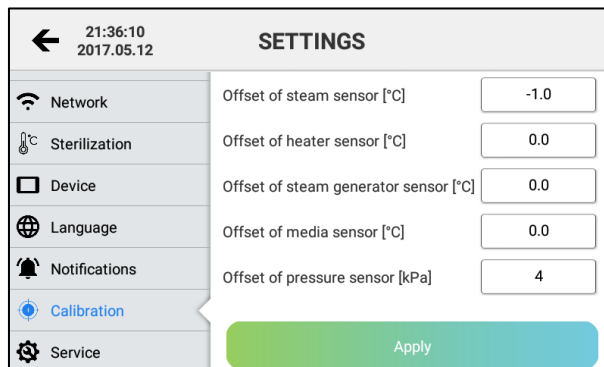

4. Enter an offset for the pressure sensor in [kPa], so that the blue front panel LCD screen shows a pressure of 0 kPa. For example: If the blue front LCD screen shows a pressure of +5 kPa, then enter

a value of -4 kPa into the offset field. Press the Apply-button to save the parameters permanently.

	<p>The autoclave might not run if the user does not adjust its atmospheric pressure before first use.</p>
-----------------------------------------------------------------------------------	-----------------------------------------------------------------------------------------------------------

7.5 Validation and calibration

All sensors of the autoclave have been validated on date of manufacture. For calibration purposes, the autoclave has an G1/4 calibration port on the chamber. If a calibration on place of installation is required, please contact your distributor or directly support@certoclav.com to get a detailed service manual with instructions for validation and calibration of the internal sensors.



8 List of available sterilization programs

Program name	Number of Pre-vacuum times	Sterilizing time [min]	Sterilizing temperature [°C]	Sterilizing pressure [kPa]	Vakuum persist time [min]	Drying time [min]
121°C SOLID	1	20	121	110	-	3
121°C POROUS	3	20	121	110	-	7
121°C HOLLOW	3	20	121	110	-	10
134°C SOLID	1	4	134	210	-	3
134°C POROUS	3	4	134	210	-	7
134°C HOLLOW	3	4	134	210	-	10
USER DEFINED	1-10	1-60	105-134	20-210	-	0-40
B&D TEST	3	3.5	134	210	-	7
VACUUM TEST	-	-	-	-80	15	-
CLEAN	3	5	105	20	-	10
PRIONS	3	19	135	210	-	10
LIQUID	-	20	121	110	-	0

- The 121°C-programs and 134°C-programs have no difference in sterilization results. If the instruments cannot be sterilized in 134 °C, please choose 121°C program. The program parameters: Number of pre-vacuum-times, sterilizing time, sterilizing temperature, sterilizing pressure, drying time can be adjusted.
- The 121°C Solid and 134°C Solid programs can only sterilize solid instruments which are not wrapped. For example cleaning pistols, bottles, peelings, pliers and forceps. The program parameters: Number of pre-vacuum-times, sterilizing time, sterilizing temperature, sterilizing pressure, drying time can be adjusted.
- The 121°C Porous and 134°C Porous programs can sterilize materials which are made of porous material. The program parameters: Number of pre-vacuum-times, sterilizing time, sterilizing temperature, sterilizing pressure, drying time can be adjusted.
- The 121°C Hollow and 134°C Hollow programs can sterilize the hollow bodies of type A and B according to EN ISO 13060. The program parameters: Number of pre-vacuum-times, sterilizing time, sterilizing temperature, sterilizing pressure, drying time can be adjusted.
- User-defined program: The program parameters, Number of Pre-vacuum-times, sterilizing time,

sterilizing temperature, sterilizing pressure, drying time can be adjusted. The user defined program can't be used for liquid sterilization with media temperature sensor.

- The B&D Test (Bowie-Dick Test) is a test to measure the performance of the pre-vacuum of medical class b steam sterilizers. The test simulates a load of 7 kg tightly bundled textiles. Please check the color indicator of a B&D test indicator for B&D validation. The B&D test program must also be used for the Helix test. For Helix test, a process challenge device (PCD) must be used for validation.
- The Vacuum Test is an air leakage test. The vacuum test must be started after installation and maintenance. It's recommended to perform the vacuum test regularly.
- The Clean program is for cleaning the autoclave and loads. If the autoclave shows "NEED CLEAN" on the front LCD panel, then run the Clean program. The Clean program can be used to clean loads.
- Prion program: This program is to sterilize prion contaminated materials, rubbish and instruments.
- Liquid program: The sterilization of liquids, filled in bottles. It's recommended to place the flexible media sensor into one reference bottle with liquid. Only in this case, a proper sterilization of liquids can be guaranteed and stored into the protocol. Please fill the bottles only half-full to avoid the risk of scalding during removal of the bottles after sterilization.

	<p>The Bowie-Dick Test is not to be considered a biological performance test. It is intended only to forewarn the user that the air removal system has deteriorated in performance and should be corrected before sterilization problems occur as indicated by a biological indicator failure.</p>
	<p>Please don't put sealed bottles, bags or containers in the autoclave. They can explode because of overpressure.</p>
	<p>It is recommended to do a vacuum test every month. If the result is FAIL, do not use the autoclave anymore and call your local distributor or support@certoclav.com directly.</p>

9 Basic operation

Click and slide

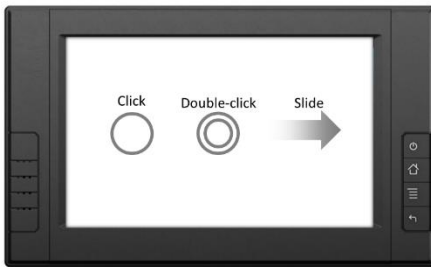

Long-press and drag

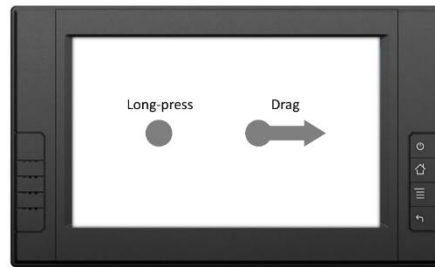

9.1 Turning on the autoclave

1. Press the -button at the front right of the touchscreen for at least 3 seconds.
2. Turn the green power switch of the autoclave on.



9.2 Turning off the autoclave

Please press the -button at the front right of the touchscreen for at least 3 seconds. A notification window will pop up. Please select the "Turn off"-option, in order to turn off the touchscreen.

9.3 Turning the autoclave into stand-by

Short press the -button at the front right of the touchscreen. The background light will be switched off. Press the -button again to wake up the touchscreen.

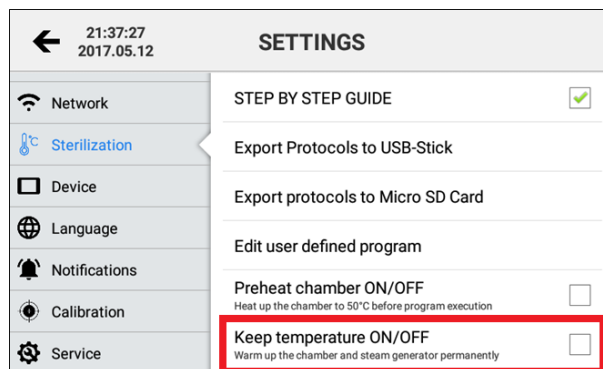

You can keep the chamber of the autoclave at 50°C for at maximum 6 hours in stand-by to optimize the batch time. To activate or deactivate this function navigate to Settings->Sterilization->Keep temperature ON/OFF and activate the Checkbox.



10 Instructions for daily use

10.1 Preparation before using

1. If the autoclave is turned off, turn on the autoclave (See chapter 9.1)
2. If no error, warning or notification is visible on the screen, the autoclave is ready to use.



	<p>Please ensure the autoclave is well grounded.</p>
	<p>Before the first usage, the touchscreen will display the notification “Please fill water in the autoclave”. As soon as the water is filled in the message will disappear and the autoclave is ready to use.</p>

10.2 Refilling water



If the LCD shows “Please fill water”, the water inside of the autoclave is not enough to start a new sterilization cycle. It’s required to fill water before starting a new sterilization cycle. If the LCD shows the message “Please fill water” during a sterilization cycle, it is not required to stop the current sterilization cycle because the water inside of the autoclave is still enough for the current cycle. But to start the next cycle, it’s required to refill water firstly. To refill water, open the water tank lid on top of the autoclave and fill in distilled or de-ionised water only. See picture above.

During refilling water, a “peep”-sound notifies the user, that the minimum amount of water for to start the next cycle has been reached. The user can stop or continue filling water. Please be careful not to overfill the clean water container. If the water tank has been overfilled, its possible to drain water from the quick-connect drain connector on the front of the autoclave.

	<p>Only distilled water can be used for this autoclave. Otherwise, there will be a problem with the steam generator and solenoid valves. The user shall be responsible for the problem if he/she uses other kinds of water.</p>
	<p>Before filling water, please turn on the autoclave and ensure the autoclave is horizontal. After filling water, if possible, please drain the waste water.</p>
	<p>Only fill demineralized or distilled water in the fresh water tank. A water quality sensor continuously monitors the water quality of the filled in water. A warning notification appears on the integrated LCD screen appears if quality of the filled in water isn’t good enough.</p>

10.3 Steps to start a cycle

If the touchscreen doesn't show any errors or warnings, the autoclave is ready to work.

10.3.1 Selection of a program

1. After login, navigate to the sterilization tab.
2. In the middle are 4 programs visible. Please scroll the vertical scrollable list down to browse through all 12 available programs.
3. Click on the "Start"-Button to choose and start a program.
4. Please confirm the dialog to start the program.
5. If CertoTrace is enabled, the tracing assistant will be opened.
6. If the step-by-step guide is enabled, a video step-by-step guide will be opened.

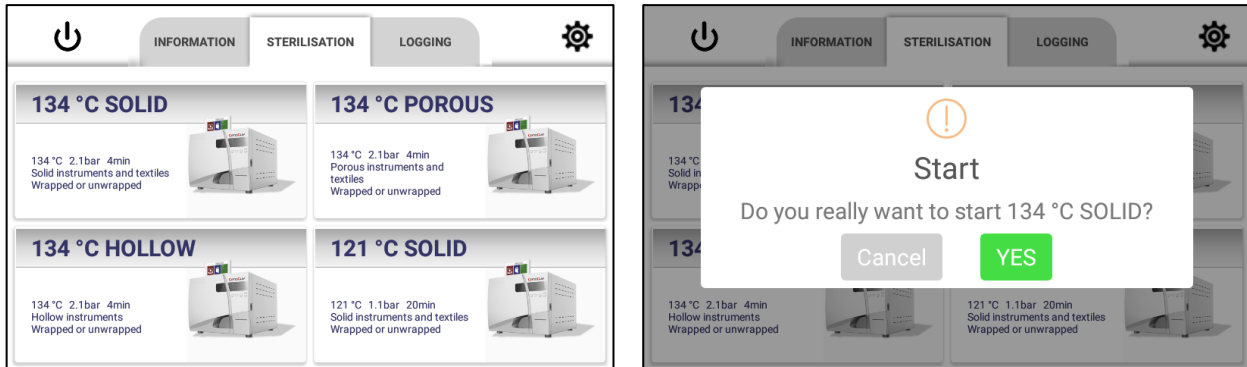

10.3.2 CertoTrace – Decontamination process documentation

CertoTrace is a feature, enabling simple and professional documentation across the whole instrument decontamination process

- 1) If CertoTrace is enabled (Settings -> Sterilization -> CertoTrace load documentation), the CertoTrace assistant will be shown after starting a program. Please note: The CertoClav barcode scanner and label printer is necessary in order to take advantage of the CertoTrace load documentation system.
- 2) Please scan the barcode of the items, which are going to be placed into the autoclave chamber.

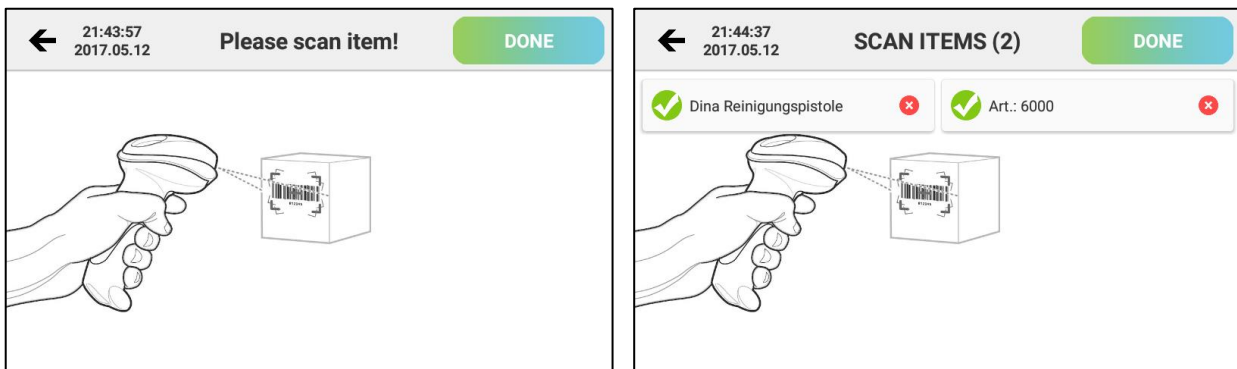

- 3) After scanning an item, it will appear on a scrollable list of items, shown in the CertoTrace assistant menu. The item name and article number will be stored into the forgery protocol record.
- 4) After scanning all items, press the Done-button.
- 5) To cancel the CertoTrace Assistant, press the Back-button on the top left corner of the screen.
- 6) Please note: If no barcode label for a specific item exists yet, the user can use the label printer designer tool to print custom labels. The Label printer designer is located under Settings->Sterilization->Label printer designer.
- 7) If enabled, the step-by-step guide will be shown after pressing the done button.

10.3.3 Step-by-step guide

If the step-by-step guide is enabled (Settings -> Sterilization -> step-by-step guide), the step-by-step guide will be shown after choosing a program. The step-by-step video assistant will guide the user through all steps, necessary to prepare and load the autoclave correctly.



Press the Next-Step-button to navigate through the open the monitoring menu.

10.3.4 Load the autoclave

	Ensure the total CBM of the loads is less than 70% of the CBM of the chamber.
	Keep the loads away from the surface, air outlet of chamber. Keep the loads at least 10mm away from the inner side of the chamber
	When putting into and taking out the loads, you shall use the tool attached to prevent your hands from touching the hot surface.
	If you do B&D test, you need to put the test paper at the center of the sterilization package to ensure the reliable test result.

10.3.5 Close the autoclaves door

	If the temperature and pressure inside the chamber are high, the door will be difficult to be closed. We suggest to close the door quickly, or, you can wait 30 seconds, then close the door.
--	-----------------------------------------------------------------------------------------------------------------------------------------------------------------------------------------------

10.3.6 Material testing mode – Automatic repeating start

If material testing mode is enabled (Settings -> Sterilization -> Material testing mode), the autoclave will ask how often the choose program should be executed after another fully automatically.

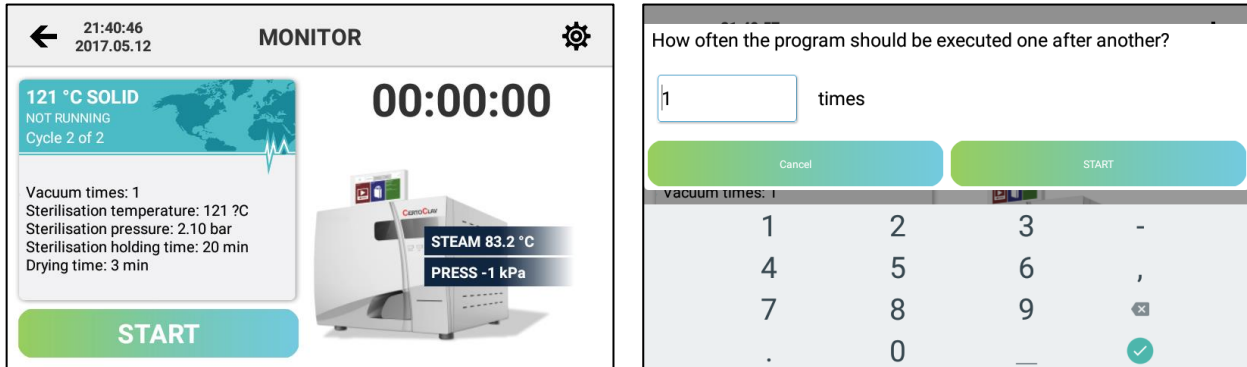

It's possible to enter any desired number from 1 to 1000. If an warning or error occurs during execution, the autoclave is able to report service staff of your choice via E-Mail and SMS.

If the user is registered at CertoCloud, which is a free autoclave management software for this autoclave, the live-status and protocol information about each recorded cycle will be automatically uploaded to the CertoCloud. The user can access the CertoCloud via www.certocloud.com from PC, tablet-PC and smartphone to check the current status of the material test.

We recommend to order the CertoClav R/O-System (Order number: 8500499) together with the autoclave in order to take maximum advantage from the material testing mode. The R/O System refills the autoclave fully automatically with distilled whater, so that no staff is necessary to operate the autoclave during the test.

10.3.7 Autoclave status screen



During program execution, the status screen is visible. On the left side is information about the current cycle listed. On the right side of the screen are the current steam temperature and pressure visible. If the liquid program has been started, also the liquid temperature is visible.

To show a graphical view about the temperature and pressure profile of the current cycle, please hold your finger on the autoclave and swipe it to the left. Then, a graph of logging history becomes visible.



10.4 Unload the autoclave

When the sterilization cycle is finished, a message on the screen will show "Program finished – Please open door". A notification alarm sounds 3 long beeps. The user can then open the door and take out loads inside the chamber.

	<p>You shall use a tray-holder tool when taking out loads to prevent scald. Don't open the door until the pressure is within a range from -05 kPa to +05 kPa.</p>
	<p>To ensure the effectiveness of sterilization, during daily use, we suggest putting test paper or pouches with indicators together with the loads into the sterilization chamber.</p>

10.5 Drain water from waste water tank

If The LCD shows "Please drain water from the waste water tank!", the waste water tank is full, the user must drain the waste water.

	<p>The waste water might be very hot, please be careful when you are draining them</p>
-----------------------------------------------------------------------------------	----------------------------------------------------------------------------------------



10.6 CertoCloud software for PC

The CertoCloud is a web based management software for your autoclaves. CertoCloud can be reached at on any browser at www.certocloud.com via PC, Smartphone and Tablets.

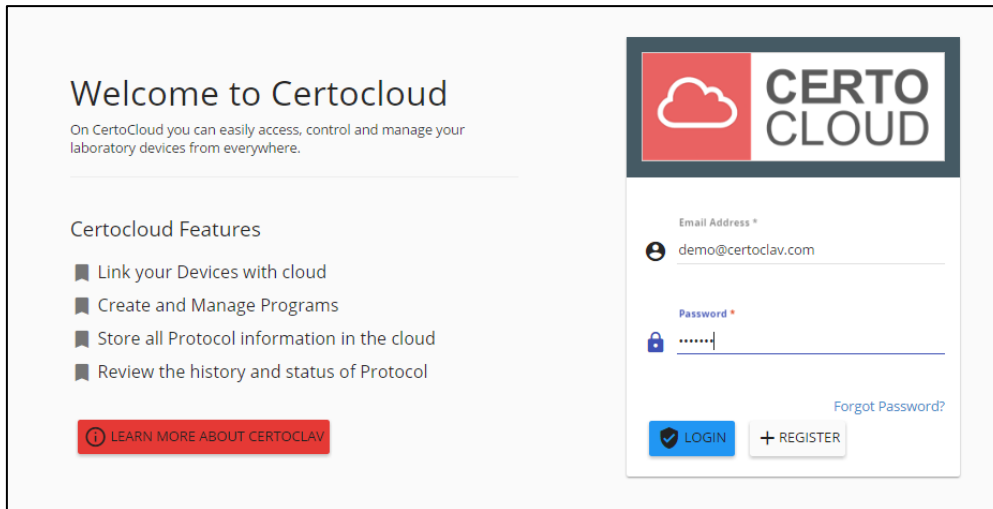

Register a user account, direct at the autoclave or at www.certocloud.com.

View Real-time data of the autoclave via the internet

Management of SMS and e-mail notifications. For instance, if a service is due.

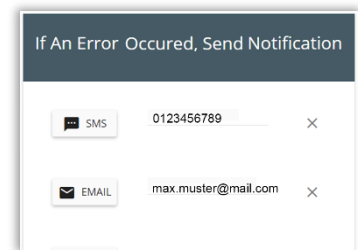
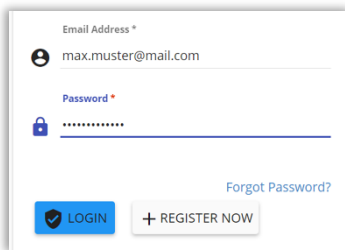

Download of all sterilisation protocols as signed PDF, Excel and ZIP file.

View graphical representation, a list or a detailed view of all protocols.

Prove the validity of the exported protocols.

Cycle	Program Name	Start
76	cloud generated	7/22/ PM
75	121°C SOLID	7/22/ PM
74	Neues Programm	7/22/ PM
74	121°C SOLID	7/22/ PM

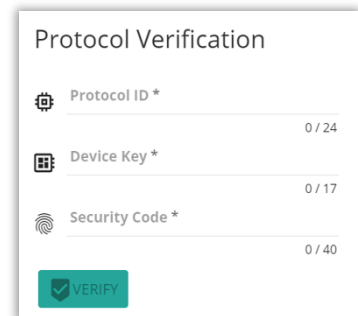
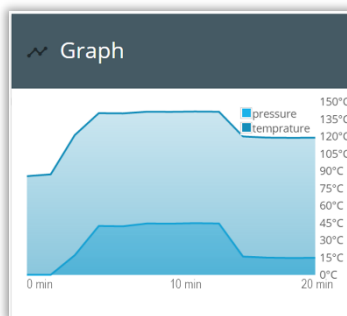

11 Autoclave menu overview

11.1 Login menu

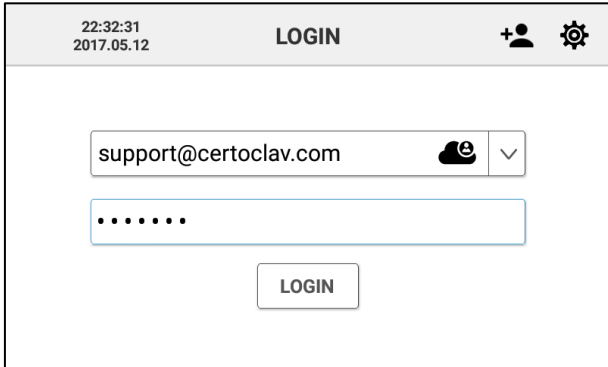

After switching the Certotouch on, the login window will appear. In order to login with the administrator account, enter the standardpassword "admin". This password can afterwards be changed in the user settings. To login with your personal account, press on the user name and choose your email address from the list.

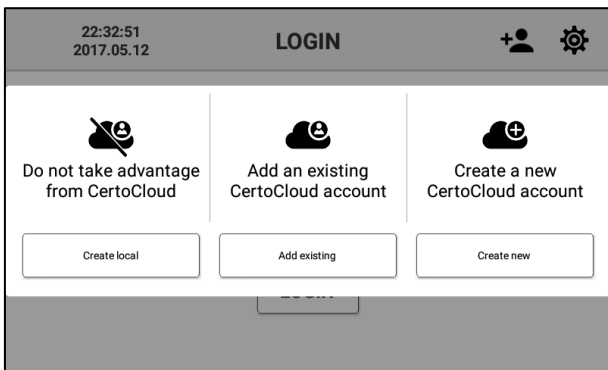

To add an existing CertoCloud account or to create a new user account click on the -button at the top right of the screen. A dialog appears. To create an account without CertoCloud connection, press the "local" button. To add an existing CertoCloud account to the device, press the existing button. If you don't have a CertoCloud account yet, press the "Create new" button. To create a new CertoCloud account an internet connection via ethernet or Wifi is required.

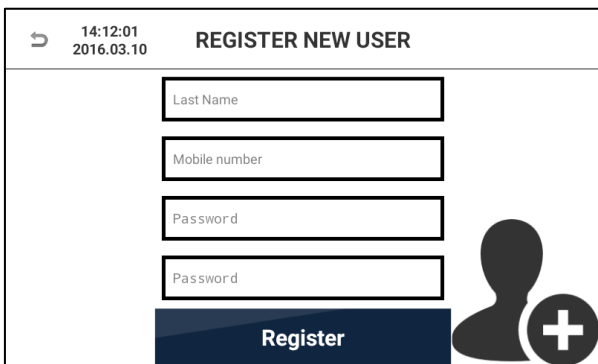

To create a local account, enter your user date. The textfields can be selected and edited by a click on the textfield. Enter the complete mobile phone number including the international prefix. That number is necessary if the status messages per SMS are enabled. Please choose a password with at least 4 characters and retype it Confirm the user registration, by clicking the "Register user" button. To abort the registration press the back button. To complete the registration, press the "Register" button

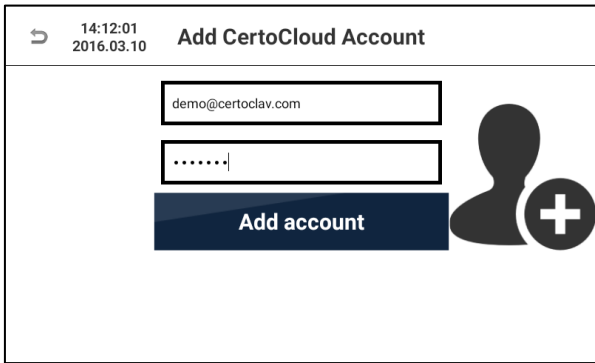

To add an existing CertoCloud account, enter the e-mail address and the password. Afterwards press the “Add account” to confirm the account. To abort the registration, press the back button on the left top of the screen.

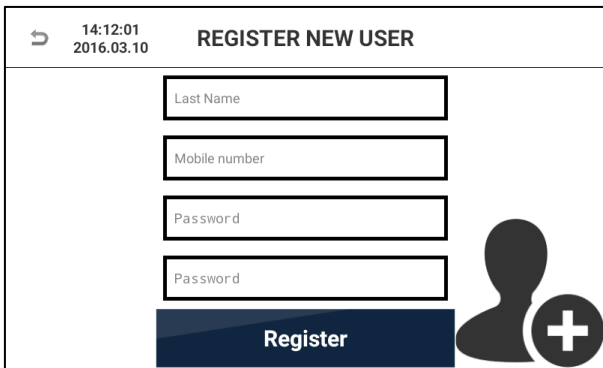

To create a new CertoCloud account, enter your user data into the appropriate textfields. Please enter your phone number with the international prefix. To validate your phone number and e-mail address an e-mail and a SMS will be send to your e-mail and your phone. Please enter your password twice and press the “Register”-button.

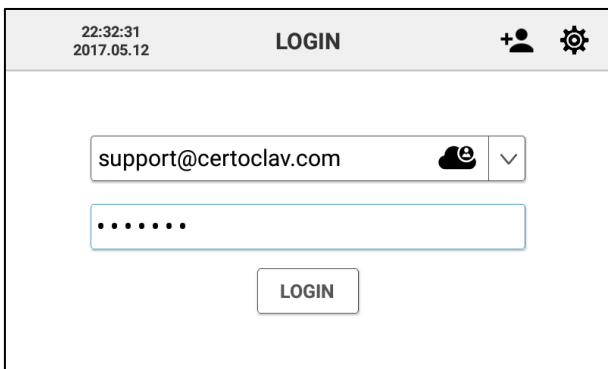

To login with the created user account, choose your email address from the list and enter your password.. Please make sure that the online mode is enabled. The online mode settings can be found under: Settings->Network->Online Mode.



If you log in for the first time, you will be asked for an activation key. You received the activation key via e-mail and via SMS, after the registration of the CertoCloud account. Please enter the activation key in the textfield and press the “Activatie account”-button. Your CertoCloud account is now activated and you can now use the CertoCloud account with your autoclave.

11.2 Information menu

Please navigate to the “Information” tab to contact CertoSupport via email directly from the touch screen. It is also possible to watch step-by-step videos and to open the CertoClav web-shop.

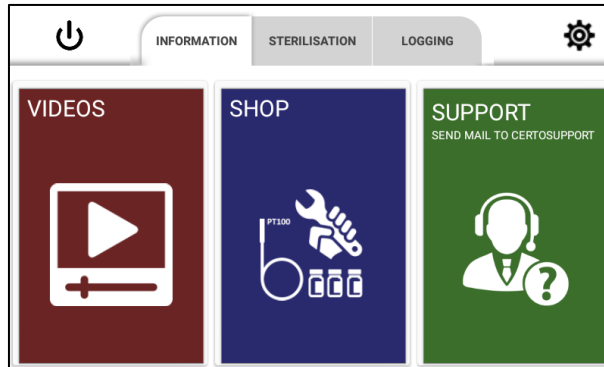

11.2.1 Tutorial videos

To scroll through the list of available videos, click on the video section in the information tab. Click on the desired video to watch the video in full screen.

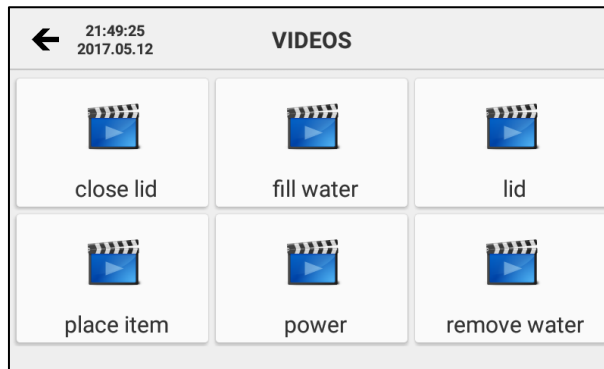

11.2.2 How to send an e-mail to CertoSupport

The device must be connected to the internet to send an e-mail to CertoSupport direct from the device. To connect the device to the internet you can use the ethernet port of the device or a WiFi network.

Click on the “SUPPORT”-button to open the e-mail window.

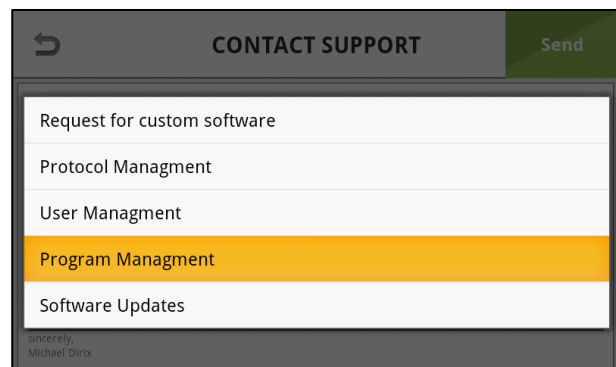
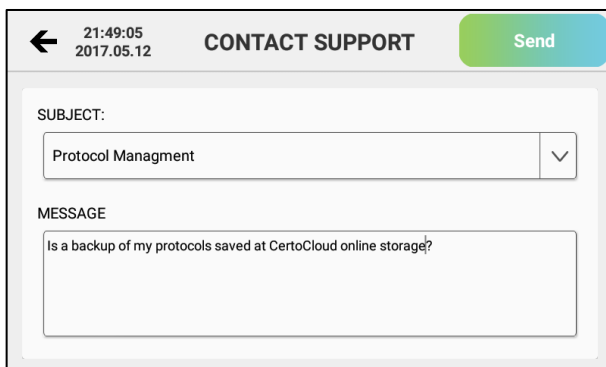

Choose a subject for your message to CertoSupport from the drop-down menu.

Afterwards enter your message to CertoSupport in the message textfield. To send the message, click on the “Send”-button. A reply to your request will be send to the e-mail address of your autoclave account within 24 hours.

11.2.3 TeamViewer remote support via screen sharing

To start a TeamViewer screen sharing session with CertoSupport, navigate to Information-Tab and press the Support-button. On the following dialog, choose the screen sharing option. The TeamViewer request will only be accepted if a specific time has been agreed by your distributor or CertoSupport via E-Mail or phone. To request a time frame for the team-viewer session, please navigate to the Information-Tab and press the Support-button. Choose the option to send an E-Mail to CertoSupport and ask for an time frame. Generally your request will be answered within 12 hours.

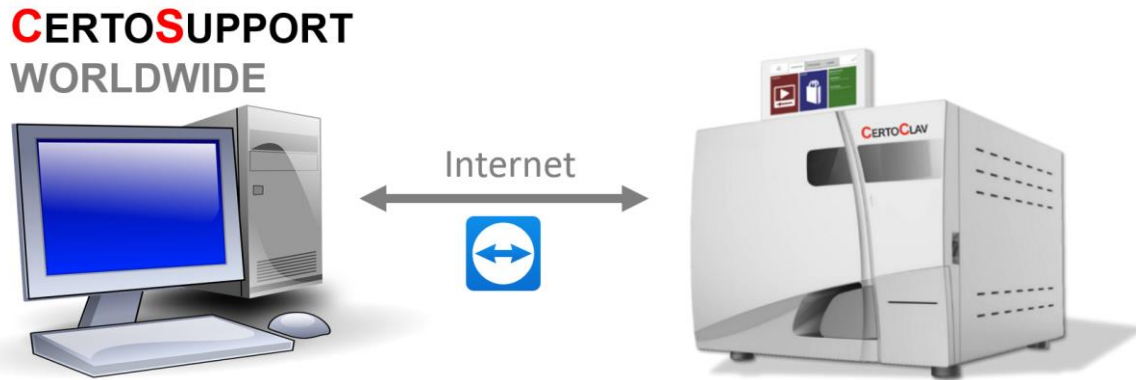

Navigate to the Information-Tab and press the Support-button on the right side of the screen. A dialog will open and asks for the desired method of support. If you don't have agreed a time frame for TeamViewer screen sharing with CertoSupport yet, please choose the Send Email option and ask CertoSupport for a screen sharing appointment. If you already have an appointment for a screen sharing session with CertoSupport or your distributor, then choose the Share Screen option.

A window will appear, where you can add a problem description to your screen sharing request optionally.

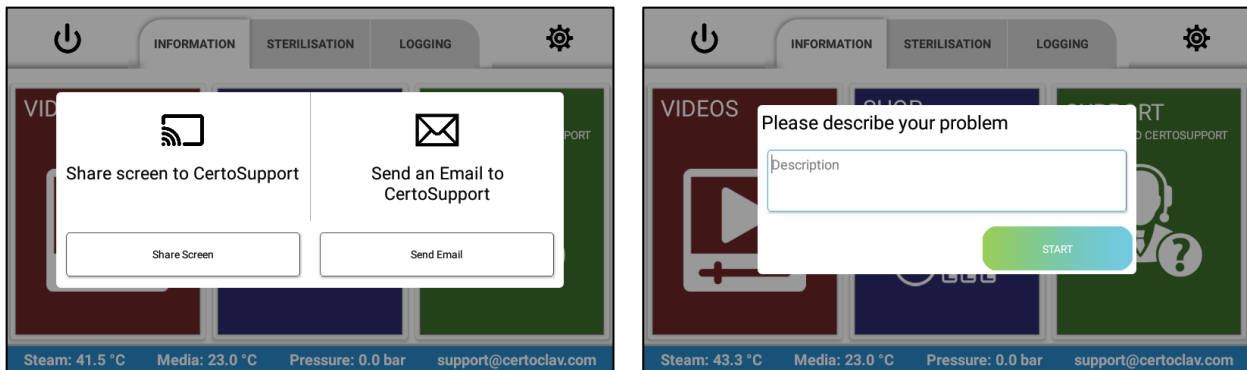

Press the Submit-button and wait until CertoSupport joins the Screen sharing session. In order to share the autoclave screen, press the Allow-button. Not the CertoSupport is able to control the autoclave remotely. To cancel a running screen sharing session, drag the TeamViewer-icon from into the bottom of the screen.

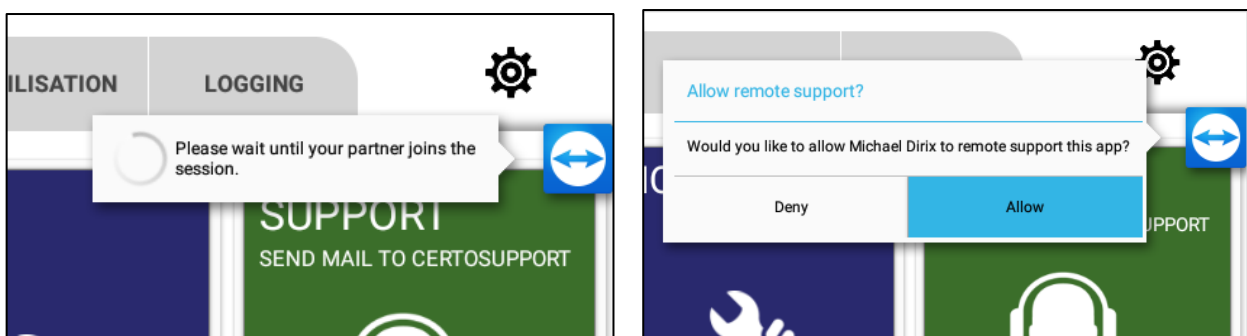

11.3 Sterilization menu

1. After login, navigate to the sterilization tab.
2. In the middle are 4 programs visible. Please scroll the vertical scrollable list down to browse through all 12 available programs.
3. Click on the “Start”-Button to choose and start a program.
4. Please confirm the dialog to start the program.
5. If CertoTrace is enabled, the tracing assistant will be opened after start.
6. If the step-by-step guide is enabled, a video step-by-step guide will be opened after start.

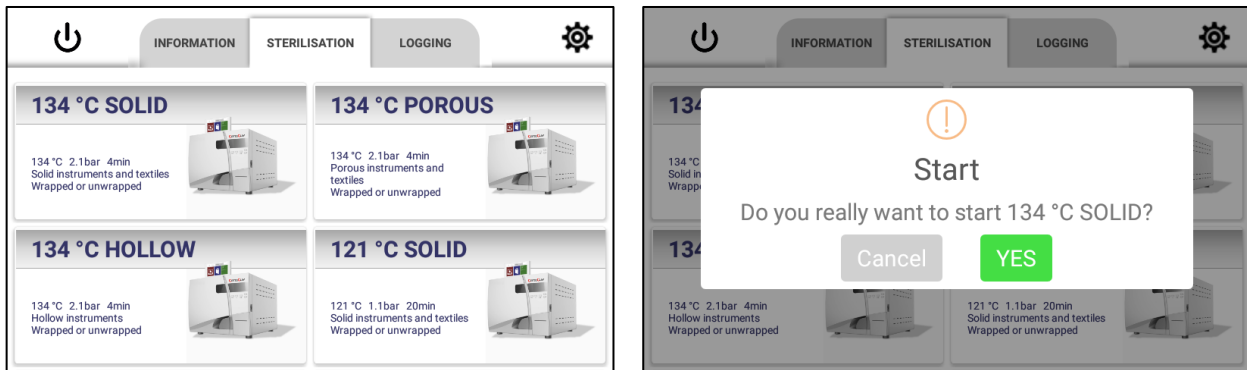

11.4 Logging menu

11.4.1 View protocols

Navigate to the protocols tab to view the sterilization protocols. A list on the left side of the screen shows all recorded protocols. The cloud icon in the protocol list indicates if the protocols are synchronized with the CertoCloud (www.certocloud.com) or not. An internet connection is required for the synchronization. Click on the drop-down menu above the protocol list to change the order criteria. Click on a list element to view the details and graphical view. The graphical course is displayed on the right side of the screen.

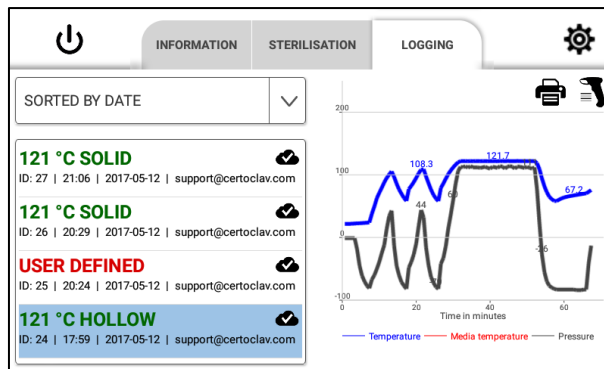

11.4.2 Print protocols

- 1) Navigate to the Logging-Tab
- 2) Scroll to the protocol of your choice in the protocols list on the left side of the screen
- 3) Press on the protocol list entry to show a detail view on the right
- 4) Press the print button on the upper right of the screen to open a print dialog
- 5) Press the Print protocol-button to print the protocol via the protocol printer

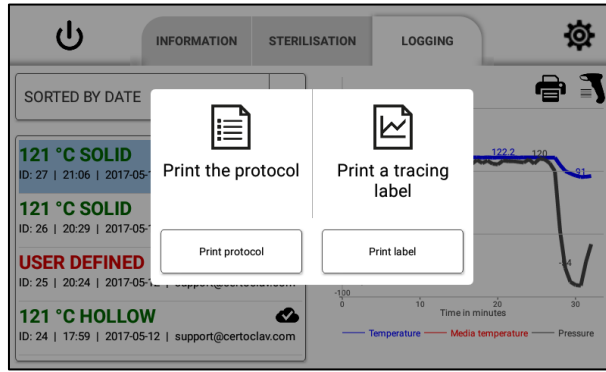

11.4.3 Print tracing label

- 1) Navigate to the Logging-Tab
- 2) Scroll to the protocol of your choice in the protocols list on the left side of the screen
- 3) Press on the protocol list entry to show a detail view on the right
- 4) Press the print button on the upper right of the screen to open a print dialog
- 5) Press the Print label-button
- 6) Enter the date of expiration. Of the sterilized item. Per default it is set to 6 months
- 7) Press OK to print the label including tracing barcode.

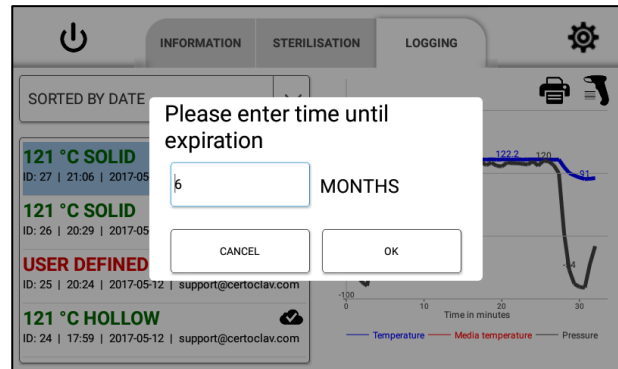
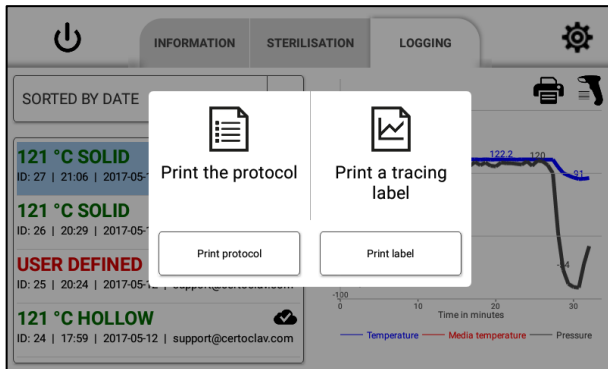

11.4.4 Tracing of labeled items

- 8) Navigate to the Logging-Tab
- 9) Press the scan-icon on the top right of the window
- 10) A popup window appears. Please scan the barcode of the labeled sterilized item with the barcode scanner
- 11) The protocol of the sterilized item will be highlighted on the left of the screen. On the right side of the screen you can see the graphical view of the protocol. If the sterilization cycle was not successful, an error notification will be shown on the right side of the screen.

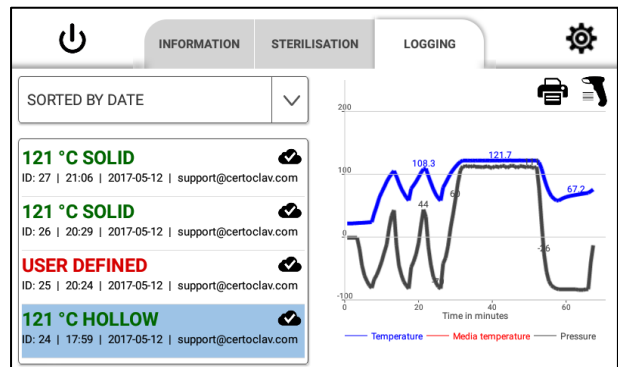
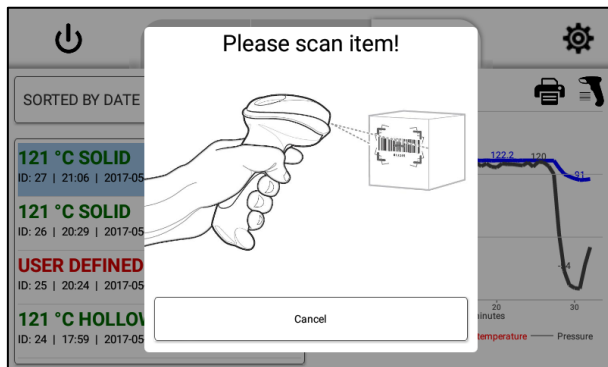

11.5 Monitor menu

During program execution, the autoclave monitor screen is visible. On the left side is information about the current cycle listed. On the right side of the screen are the current steam temperature and pressure visible. If the liquid program has been started, also the liquid temperature is visible.

To show a graphical view about the temperature and pressure profile of the current cycle, please hold your finger on the autoclave and swipe it to the left. Then, a graph of logging history becomes visible.

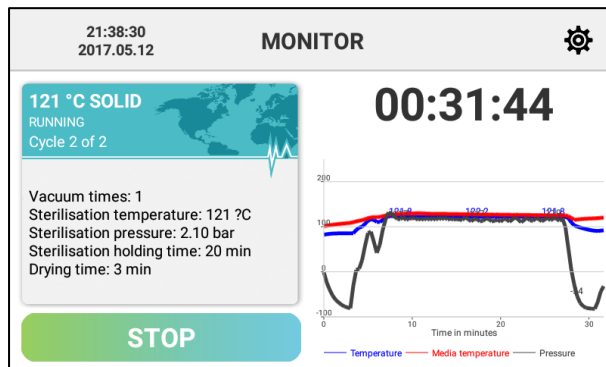

12 Autoclave settings overview

12.1 User settings

1. Navigate to the Settings menu by clicking the  -button at the top right corner of the screen.
2. Press the user management entry to view all user accounts.
3. Press the edit-button to change the user data and the password. You can only modify the account, which is currently signed in.
4. Press the delete-button to delete the account.

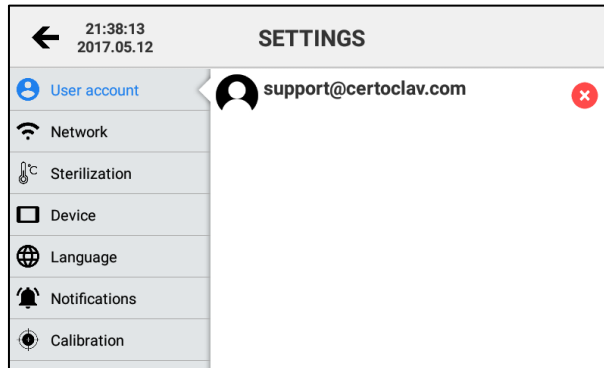

12.2 Network settings

1. Navigate to the Settings menu by clicking the  -button at the top right corner of the screen.
2. On the left side of the settings window, press the Network list entry.

12.2.1 Connect to WIFI network

1. Navigate to the Settings menu by clicking the  -button at the top right corner of the screen.
2. On the left side of the settings window, press the Network list entry.
3. If the WIFI ON/OFF checkbox is deactivated, click on the checkbox to activate Wifi.
4. Afterwards click on the MANAGE WIFI CONNECTIONS entry to show a list of available networks. Press on a WiFi network to enter password and further parameters. The WiFi network will be saved. The autoclave will connect to the wireless LAN automatically
5. Press the Return-button on the right side of the screen to close the WiFi settings and to return to the settings window.

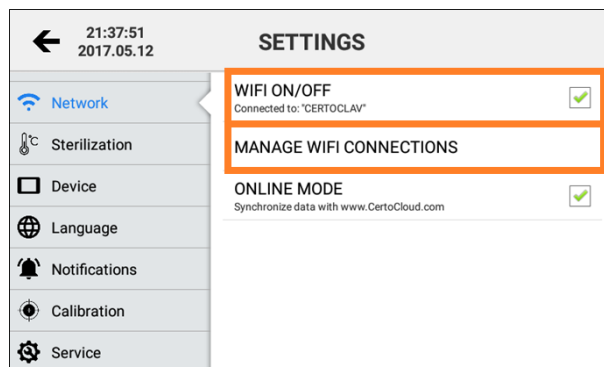

12.2.2 Connect to LAN

The autoclave can be connected to a local area network and internet via ethernet cable. Plug the ethernet cable into the ethernet socket on the extension cable.



12.2.3 Enable or disable online mode

If the user creates a CertoCloud account directly on the device or on www.CertoCloud.com, a backup of all his protocols and parameters can be saved to the secure CertoCloud online storage. In the settings menu it is possible to enable or disable the communication with the CertoCloud:

1. Navigate to the Settings menu by clicking the  -button at the top right corner of the screen.
2. Press the Network entry.
3. Press on the Online Mode entry to check or uncheck the Online Mode checkbox. A checked checkbox means, that the online mode is enabled.

Please note: In offline mode, no backup of the protocols will be uploaded to CertoCloud. In this case, the protocols are stored locally on the autoclave only. If the user wants to create a backup of his protocol data, it must be done manually via USB-stick, SD-card or printer. If the user enables the online mode, all local protocols which are not uploaded to CertoCloud yet, will be uploaded.

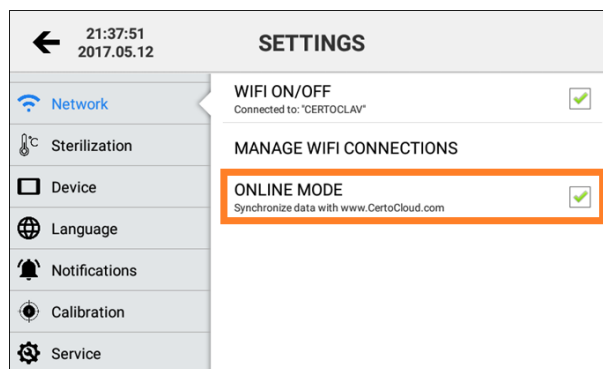

12.3 Sterilization settings

12.3.1 Record a running cycle via USB

For redundant logging, use an USB flash drive to store the sterilization protocols in real time during the sterilization process. Please insert the flash disk into USB port at the front-USB port of the autoclave



12.3.2 Export all protocols to USB flash drive

1. Navigate to the Settings menu by clicking the  -button at the top right corner of the screen.
2. On the left side of the settings window, press the Sterilization list entry.
3. Plug in a USB stick into the USB host of the extension wire
4. Press the list entry: Export Protocols to USB-Stick
5. A few USB-sticks can't be written immediately. If the export fails, let the USB-Stick plugged in and reboot the touch screen.

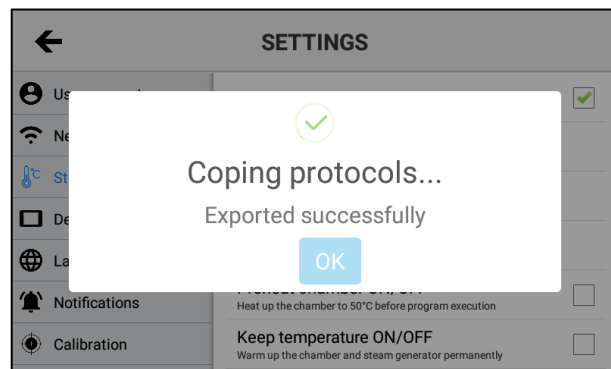
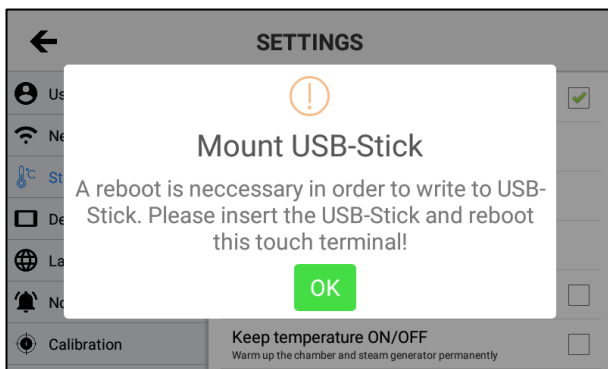
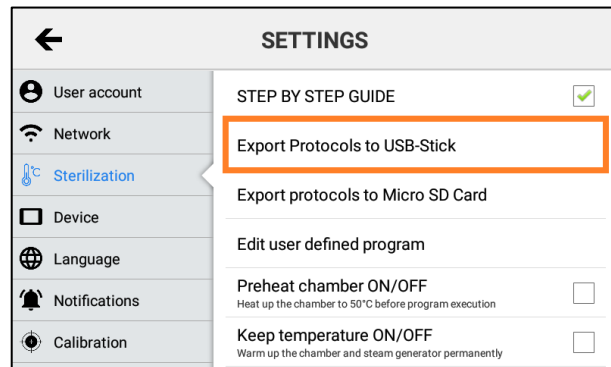

12.3.3 Export all protocols to SD-Card

1. Navigate to the Settings menu by clicking the  -button at the top right corner of the screen.
2. On the left side of the settings window, press the Sterilization list entry.
3. Plug in a micro SD-card into the SD-card slot of the touch screen.

4. Press the list entry: Export Protocols to Micro SD card

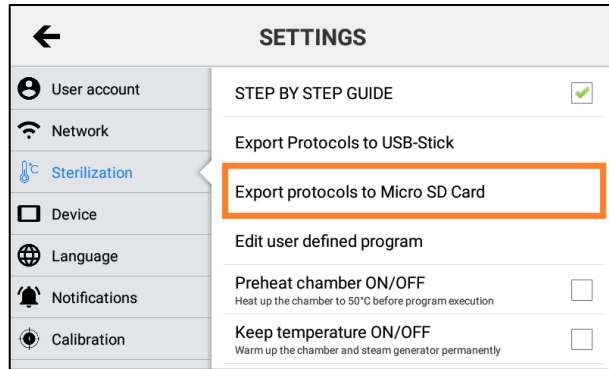
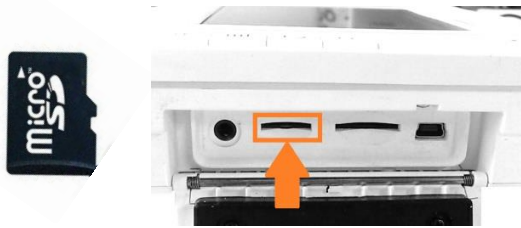

12.3.4 Export all protocols to CertoCloud online storage

1. Sign in into the touch terminal with a CertoCloud account. A backup of all protocols will be automatically uploaded to you CertoCloud online storage. The upload has been successful if the cloud icon next to each protocol in the Logging-tab is checked:

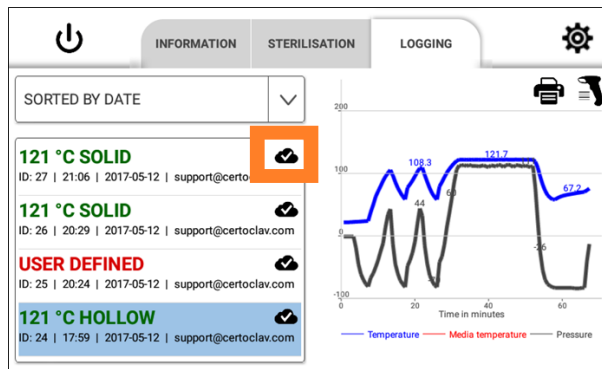

12.3.5 Change user defined program

1. Navigate to  Settings -> Sterilization -> Edit user defined program
2. A window opens, where it is possible to edit the program parameters
3. Enter a number of vacuum times between 1 and 10.
4. Enter a sterilization temperature between 105 °C and 134 °C.
5. Enter a sterilization time between 4 and 60 minutes.
6. Enter a drying time between 1 and 25 minutes.
7. Press the “apply”-button to save the parameters or press the “Cancel” to abort the process and return to the setup menu.

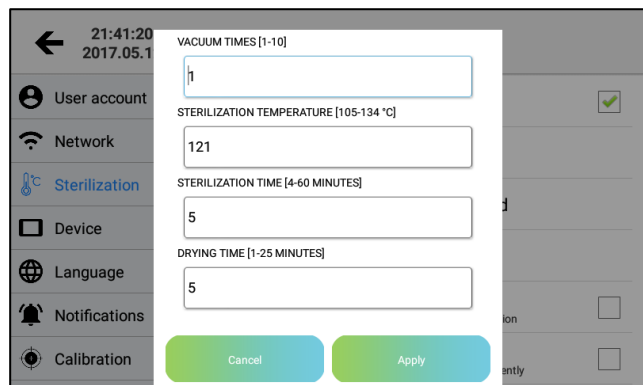
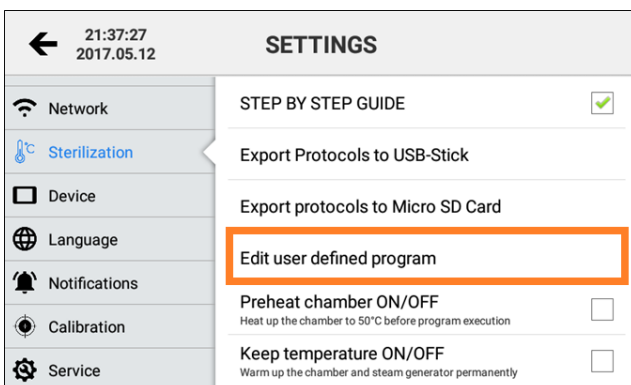

12.3.6 Preheating ON/OFF

It is advised to heat up the chamber to 50°C before the start of the vacuum time. In some countries, this is required by a law in medical field. To activate this function, navigate to the Settings->Sterilisation->Preheat chamber ON/OFF and activate the checkbox.

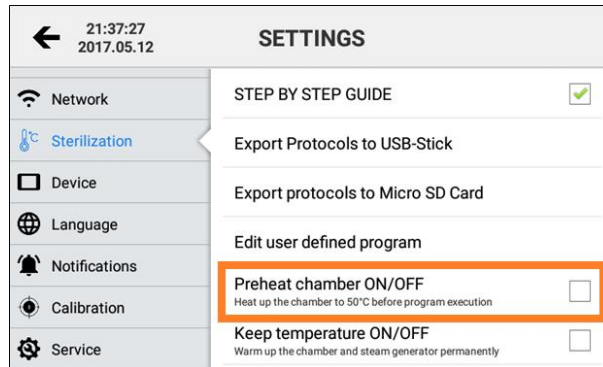

12.3.7 Keep autoclave at operation temperature ON/OFF

You can keep the chamber of the autoclave at 50°C for at maximum 6 hours in stand-by to optimize the batch time. To activate this function navigate to Settings->Sterilization->Keep temperature ON/OFF and activate the Checkbox.

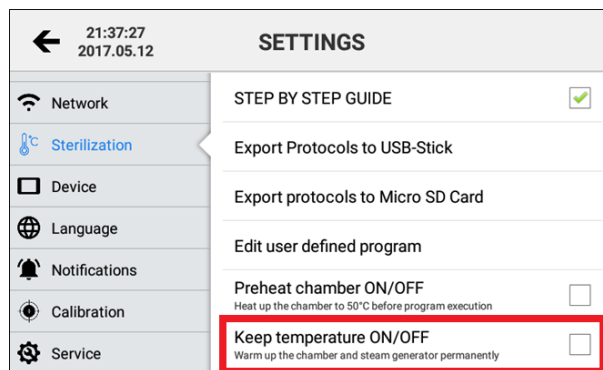

12.3.8 Step by Step assistant

1. Navigate to  Settings -> Notification.
2. Choose the entry sterilization on the left side of the settings screen.
3. Click on the step-by-step assistant to activate or deactivate the step-by-step assistant.



12.3.9 Material testing mode – Automatic repeating start

If material testing mode is enabled (Settings -> Sterilization -> Material testing mode), an additional dialog will be shown after starting a program. The autoclave will ask the user how often a program should be executed after another fully automatically.

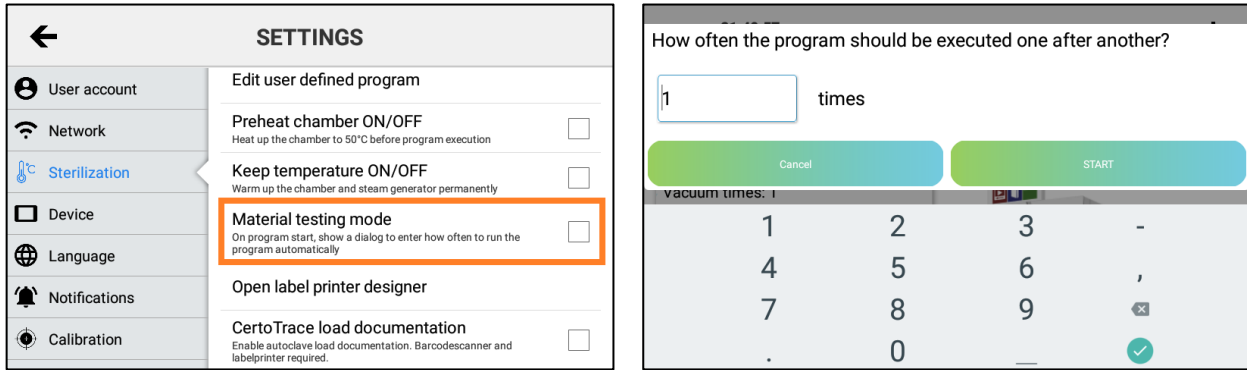

12.3.10 CertoTrace - Decontamination process documentation

1. If CertoTrace is enabled (Settings -> Sterilization -> CertoTrace load documentation), the CertoTrace assistant will be shown after starting a program. Please note: The CertoClav barcode scanner and label printer is necessary in order to take advantage of the CertoTrace load documentation system.
2. With CertoTrace, it is possible to track which item has been sterilized. The label printer will print every necessary information on the label after sterilization.

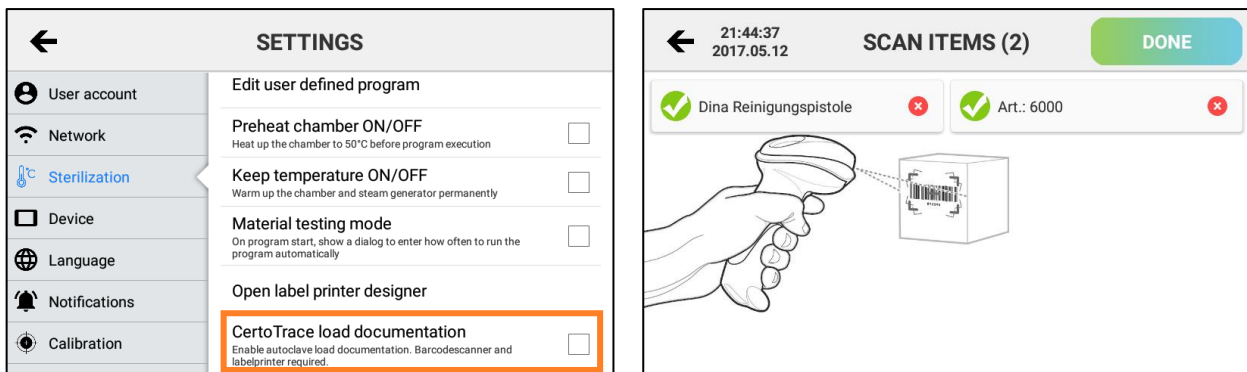

12.3.11 Label printer designer

If no barcode label for a specific item exists yet, the user can use the label printer designer tool to print custom labels. The Label printer designer is located under Settings->Sterilization->Label printer designer.

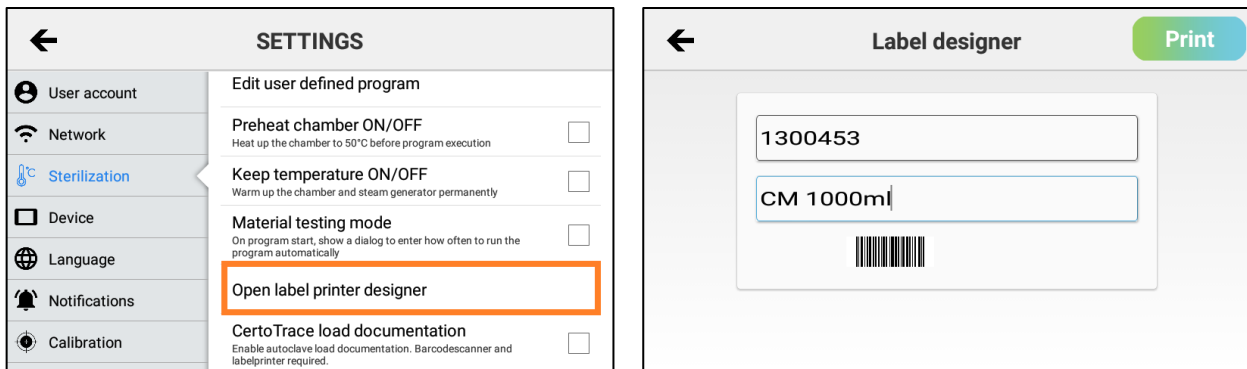

12.4 System settings

12.4.1 Change date and time

To change the date and the time of the autoclave, you have to use the build In LCD screen at the front of the autoclave. Under ADV->DATE/TIME the real time clock of the autoclave can be changed. For the navigator use the OK, UP and DOWN keys.

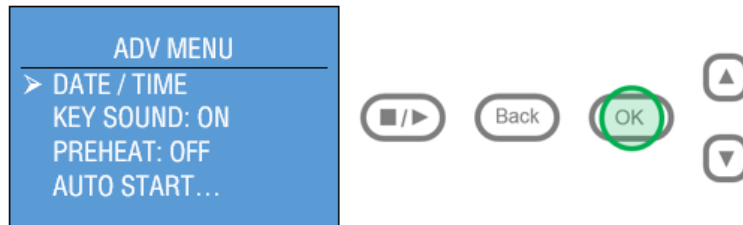

12.4.2 Check for updates over internet

1. Make sure that the autoclave is connected to the Internet.
2. Go into the Settings menu by clicking the  -button at the top right corner of the screen.
3. Please enter the "Device" section by selecting the entry "Device" on the left list.
4. On the detail view on the right, please scroll to "Check for updates" and select this entry.
5. A progress bar with the download progress will pop up. Once all updates have been downloaded, they will be installed. If a new software version is available, an installation wizard will guide you through the installation process

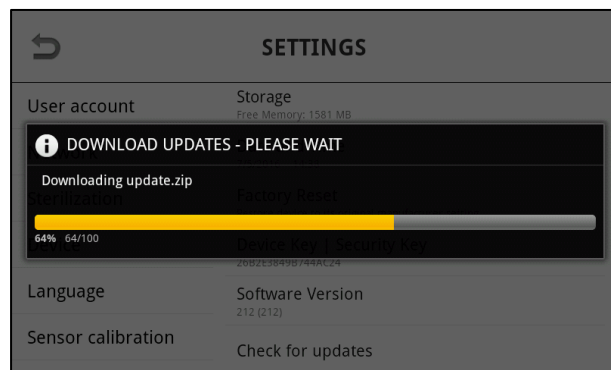
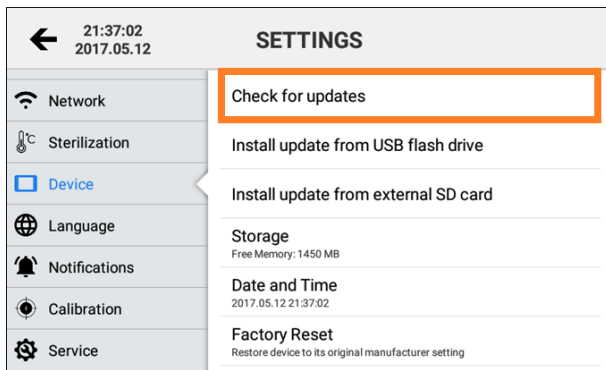

12.4.3 Install updates from USB flash drive

1. Load the newest update from www.certoclav.com or ask for the newest update for your device per mail to support@certoclav.com. Please tell our support team the serial number of the autoclave. You can find the serial number on the type label of the autoclave or under Settings->Device->Serial number. Copy the "update.zip" to the main directory of the USB-Stick and plug in the USB stick to the extension cable of the touchscreen.
2. Navigate to the Settings menu by clicking on the  icon at the top right corner of the screen.
3. Click on the entry "Device".
4. Scroll through the detailed view on the right side of the screen to the entry "Install update from USB flash drive" and click on that entry.
5. If the USB stick isn't recognized, restart the touchscreen and try it again.

6. Follow the instructions that are displayed on the screen to install the updates.

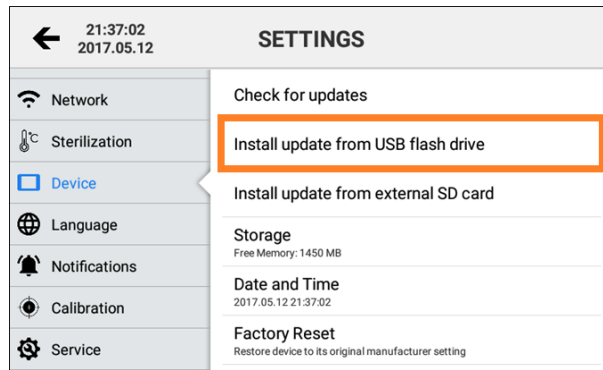

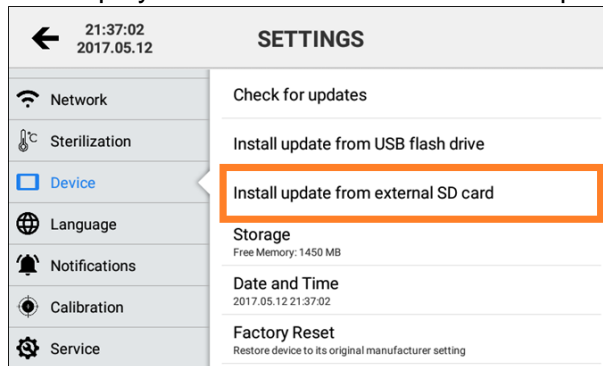

12.4.4 Install updates from external SD card

1. Load the newest update from www.certoclav.com or ask for the newest update for your device per mail to support@certoclav.com. Please tell our support team the serial number of the autoclave. You can find the serial number on the type label of the autoclave or under Settings->Device->Serial number. Copy the “update.zip” to the main directory of the USB-Stick and plug in the USB stick to the extension cable of the touchscreen.
2. Navigate to the Settings menu by clicking on the  icon at the top right corner of the screen.
3. Click on the entry “Device”.
4. Scroll through the detailed view on the right side of the screen to the entry “Install update from external SD card” and click on that entry.
5. If the USB stick isn’t recognized, restart the touchscreen and try it again.
6. Follow the instructions that are displayed on the screen to install the updates.



12.4.5 Factory reset

	If you do a factory reset, all of the not exported and not with CertoCloud synchronized protocols and user accounts will be deleted.
-------------------------------------------------------------------------------------	--------------------------------------------------------------------------------------------------------------------------------------

1. Navigate to  Settings -> Notification.
2. Click on the entry “Device”.
3. Scroll through the detailed view on the right side of the screen until the entry “Factory reset” and click on that entry.

12.5 Language settings

1. Go to the settings menu by pressing the icon in the top right corner of the screen.
2. In the settings menu, open the language setting by clicking the "Language" button.
3. In the details view on the right side of the screen, press on the current language setting.
4. See a scrollable list of supported languages. Please select by clicking the desired one.

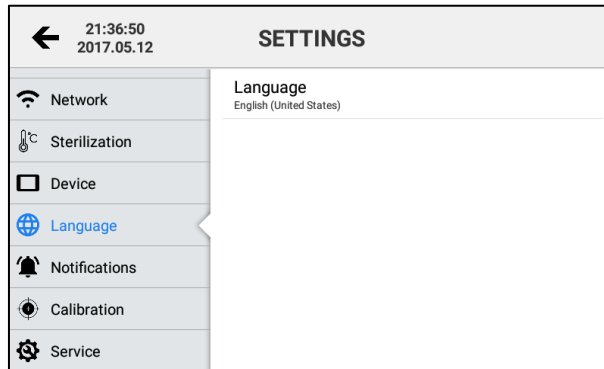

12.6 SMS and e-mail notification settings

Log in to your autoclave with your CertoCloud account. If you don't have a CertoCloud account yet, you can create a new account at the login screen. Note: To create a CertoCloud account the autoclave has to be connected to the internet.

Navigate to  Settings -> Notifications to configure SMS and e-mail notifications.

If you want to receive an e-mail if a program was aborted, service is due, or a program was finished successfully, then activate the corresponding checkbox. Enter any desired e-mail address which should receive the notifications. If you have a CertoCloud premium account, you can also deposit a mobile phone number, which should receive the SMS notifications.

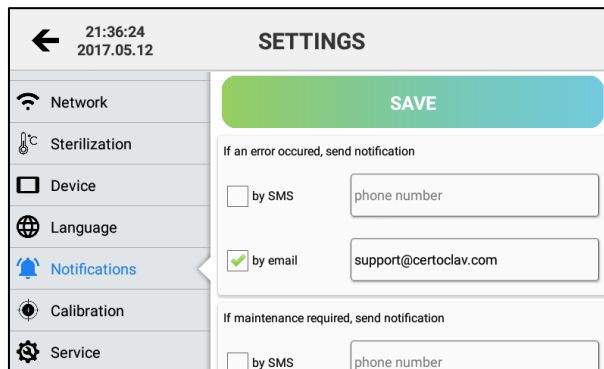

Afterwards press the "Save"-button save and apply the changes.

12.7 Sensor calibration settings

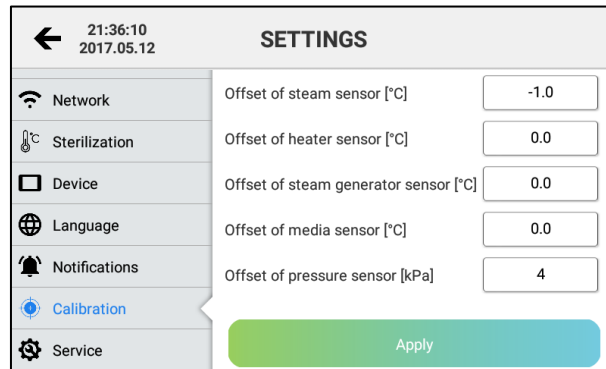

	<p>This should be only done by the distributor and trained staff</p>
-----------------------------------------------------------------------------------	----------------------------------------------------------------------

1. Navigate to  Settings -> Calibration to show the sensor offset parameters of the chamber temperature sensor, the heater temperature probe, steam generator probe or pressure temperature probe.
2. Click on the offset value of the sensor that you want to adjust and edit the offset with an interval of maximum of -3°C to +3°C respectively -10kPa to 10kPa



13 Troubleshooting

If an error occurs during the sterilization, the sterilizer will give an acoustic and visual alarm. If configured, the autoclave will also send SMS and E-Mail to the service staff. The autoclave will release the pressure and stop heating automatically. The error code will be displayed on the screen and the error will be saved into the protocol record. This safety system takes care about the safety of the user. Please power off the device after an error has been displayed and wait until the autoclave has been cooled down. Do not open the door and wait until the pressure is at atmospheric level.

	We suggest running program once more to see if the error happens again.
	Please contact your local distributor or CertoClav support (support@certoclav.com) iafter an error occurred. The autoclave repair must be done by trained service staff.

List of alarms:

Code	Condition	Possible reason	Troubleshooting
E31	The temperature of the chamber is higher than 150 °C	The sensor of the steam generator is defect.	Check if the temperature sensor (PT1000) in the chamber is plugged in correct. Change the temperature sensor if necessary.
E32	The temperature of the chamber heating is higher than 280 °C	The sensor of the steam generator is defect.	Check if the temperature sensor (PT1000) of the chamber heating is plugged in correct. If necessary, replace the temperature sensor.
E51	The temperature of the chamber is lower than 0 °C.	The sensor of the steam generator is defect or the temperature of the chamber is to low	Check if the chambertemperature is above 0 °C. Check if the temperature sensor (PT1000) in the chamber is plugged in correct. If necessary, replace the temperature sensor.
E52	The temperature of the chamber heating is lower than 0 °C.	The sensor of the steam generator is defect or the temperature of the chamber is to low	Check if the chambertemperature is above 0 °C. Check if the temperature sensor (PT1000) in the chamber is plugged in correct. If necessary, replace the temperature sensor.

E63	The temperature of the steam generator is lower than 0 °C. The temperature of the steam generator is higher than 230 °C.	Steam generator temperature sensor is defect. Steam generator temperature is higher than 230 °C. Steam generator controller instable because of the temperatures higher than 230 °C.	Check if the steam generator temperature sensor (PT1000) in the is plugged in correct. Check steam generator temperature sensor (PT1000). If necessary, replace the temperature sensor.
E2	The sterilization pressure is more than 40 kPa higher than planned.	Vacuum pump defect	Check vacuum pump and afterwards perform a vacuum test.
E61	The temperature regulation is instable. The temperature in the chamber is 6 °C higher than the required temperature	The chamber temperature sensor is defect.	Check if the temperature sensor (PT1000) in the is plugged in correct. If necessary, replace the temperature sensor.
E62	The temperature of the chamber heating is higher than 155 °C. The temperature regulation is instable.	Chamber temperature sensor is damaged. Mainboard isn't working.	Check if the chamber temperature sensor (PT1000) is plugged in correct. If necessary, replace the temperature sensor. Check the mainboard.
E41	In preheat period, after 8mins warm-up, temperature chamber heater is < 100 °C, chamber heater damaged	Chamber heating damaged	Check the chamber heater. Check the resistance of the heating rod. Check the heating rod wiring.
E42	In preheat period, after 8mins warm-up, temperature chamber heater is < 110 °C, chamber heater damaged	Chamber heating damaged	Check the chamber heater. Check the resistance of the heating rod. Check the heating rod wiring.
E5	When the period of "exhaust", after working 10mins, the pressure in chamber is still over 0.5bar : air relief instability	Output solenoid valve is blocked	Check the waste water valve. If necessary clean the valve or replace the valve.
E6	The door is opened during working. Door sensor damaged	Door damaged	Check the door sensor

E7	The local air pressure is < 70KPa Local air pressure is too low.	Wrong air pressure. Cannot use in these area.	Pressure sensor calibration. Open the door navigator to Settings->Calibration->Pressure offset change the relative pressure to 0 kPA.
E8	In pre-vacuum period, every 5mins temperature raise < 3 °C	Air leakage. No water inside tank.	Check water pump, heating rod, control board. Check water level inside tank.
E9	In sterilization period, the sterilization pressure is 0.3 bar	No water inside tank. Heater inside steam generator is	Check heaters, water pump, water level. Water pump damaged.
E10	The electronic locker is in wrong condition.	Electronic locked damaged. Circuit board damaged.	check electronic locker and circuit board
E11	The electronic locker is in wrong condition	Electronic locked damaged. Circuit board damaged.	check electronic locker and circuit board
E12	The vacuum not reach -70Kpa during at least 3 vacuum phases	Vacuum pump damaged, fan damaged.	Check the vacuum pump and the fan
E99	The communication between the front display and the mainboard isn't working	Cable is not connected. CPU IC has loosened	Check the cable between the front display and the mainboard. Check if the microcontroller-IC at the mainboard is not loose.
E-1	The program has been canceled by the user	User pressed the STOP button during the sterilization	-
E-2	The communication between the external touchscreen and the mainboard isn't working	The serial cable (COM 4) between the touchscreen and the autoclave has become loose	Screw the COM4-cable in the RS232 socket at the back of the autoclave. If the problem still persists, restart the touchscreen and the autoclave. If the problem afterwards still persists navigate to Settings->Device->Factory Reset to perform a factory reset

14 Maintenance

Below parts must be checked or replaced regularly:

1. Germ filter
2. Seal ring
3. Safety valve

Check schedule:

Part name	Checked by	Checking period	Maintenance
Door	Trained engineer	2 years	See user manual. Chapter 14.1
Seal ring	User	1 year	See user manual. Chapter: 14.2 and 14.3
Printer paper	User	After printer paper is empty	See user manual of the printer
Safety valve	Trained engineer	1 year	See user manual. Chapter: 14.4
Germ filter	User	Every 300 cycles	See service manual



14.1 Door tightness adjustment

	The door adjustment must be done by trained engineer only.
-----------------------------------------------------------------------------------	------------------------------------------------------------

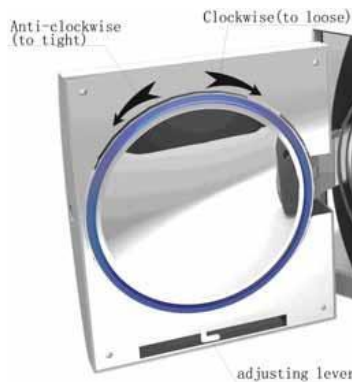
1. Open the door
2. Push down the lever and rotate the door to adjust tightness. As shown in below picture, anticlockwise turning will tighten the door, i.e., the door will be closer to the chamber. Clockwise turning the door will loosen it.



1. Release the lever
2. Keep turning the door to a place where the door cannot move anymore.

	After the door adjustment, it is necessary to perform a vacuum test. If there is a leakage, the engineer shall adjust it again
	If the door is too loose, the sealing ring might be exploded out with a big “bang”. Please make sure that the door isn’t too loose by starting the SOLID 134°C program.

14.2 Cleaning of the seal ring

The user needs to clean the seal ring regularly by distilled water. If leakage still happens after cleaning, the user may have to replace the seal ring.

14.3 Replacement of the seal ring

1. Hold the seal ring by a hand and use another one to hold a screwdriver carefully to separate the door and the seal ring. Then take the seal ring out slowly.
2. After the user takes the seal ring out, clean and check it. If it is damaged, the user must replace it.
3. After the seal ring is cleaned, assemble it.
4. Attention: if the user finds it hard to put the seal ring back, use screwdriver press it carefully until it is done.





14.4 Regular check of the safety valve

	The door adjustment must be done by trained engineer only.
-------------------------------------------------------------------------------------	------------------------------------------------------------

The safety valve must be checked regularly for visible defects. If the safety valve is damaged, it must be replaced.

1. Remove the pipe clamp (Part 1 in the figure). Afterwards remove the pipe which is connected to the safety valve
2. Remove the screw-nut (Part 2 in figure)
3. Remove the safety valve and replace it with a new one



	The new safety valve shall be same model. If you need any help, please contact your local distributor or us.
	Make sure that the power supply is disconnected during the maintenance. Only maintain the autoclave when it cools down by well-trained person.

15 Transportation and storage

15.1 Preparation

Cool down the sterilizer and disconnect the power supply.

15.2 Drainage

Empty all tanks: Assemble the pipe without joint into bleeder valve. Then turn the drainage switches towards anti-clockwise.



15.3 Terms of transportation

Because of differences between countries and distributors, contact you distributor for terms of transportation.

15.4 Terms of storage

The autoclave should be stored in the clean warehouse where room temperature is 5°C~40°C, the relative humidity is no more than 80%, no corroding gases and well-ventilated.

	Don't drag the autoclave during transportation.
--	-------------------------------------------------

16 Warranty

Warranty: 2 years. Any claims to warranty expires if any of the following conditions aren't fulfilled:

- The damage is caused by incorrect installation
- The damage is caused by negligent behavior
- The damage is caused by fall down or impact by carelessness. The damage is caused by customer's install or repair
- The damage is caused by force majeure such as abnormal voltage, fire etc.

17 Appendixes

17.1 Appendix 1: Structure diagram

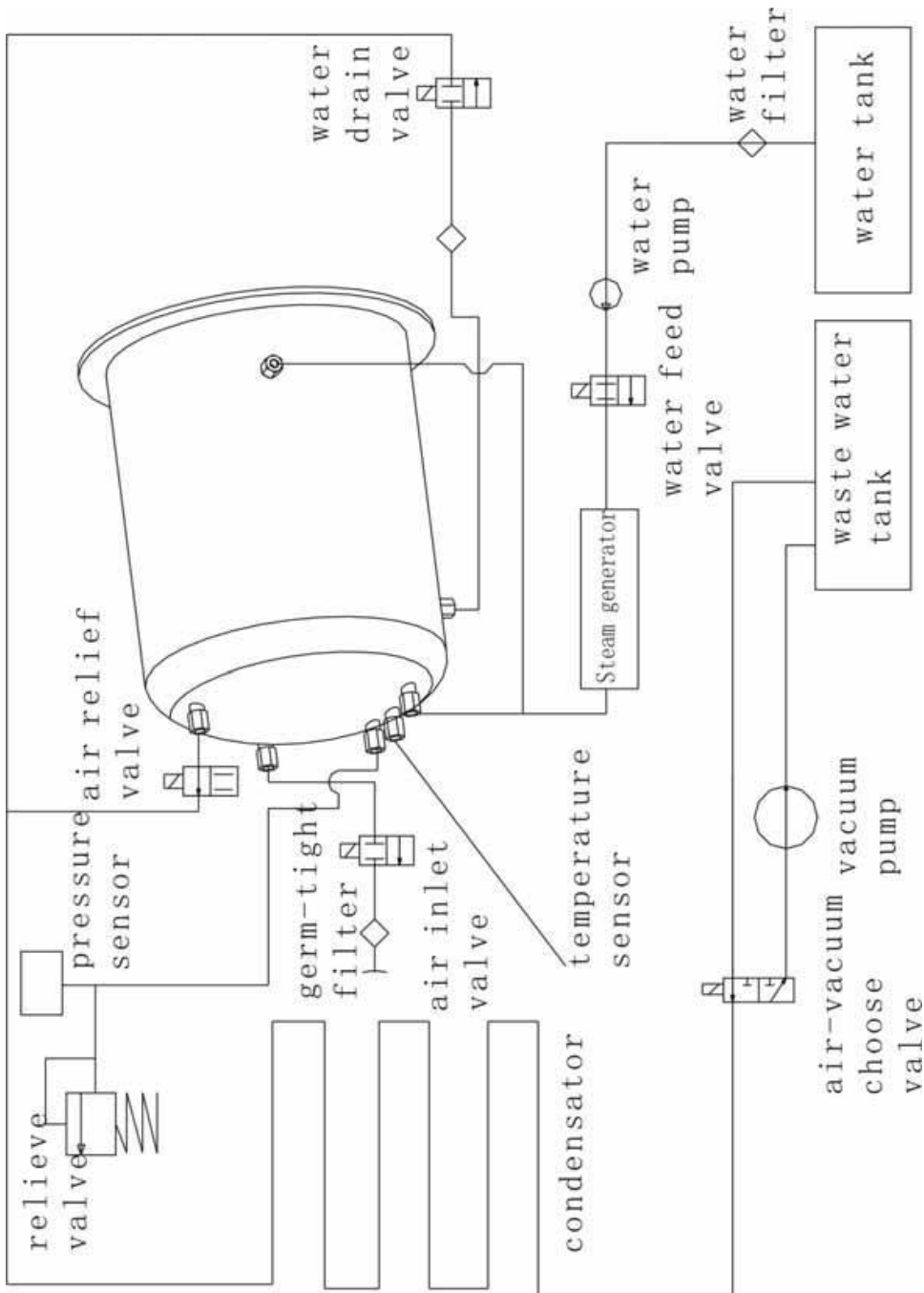

17.2 Appendix 2: Circuit diagram

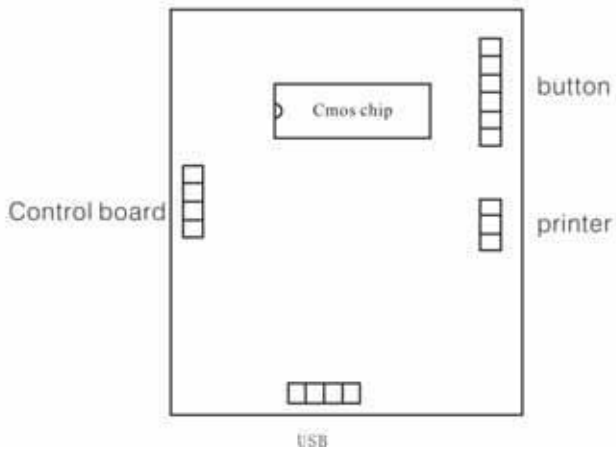
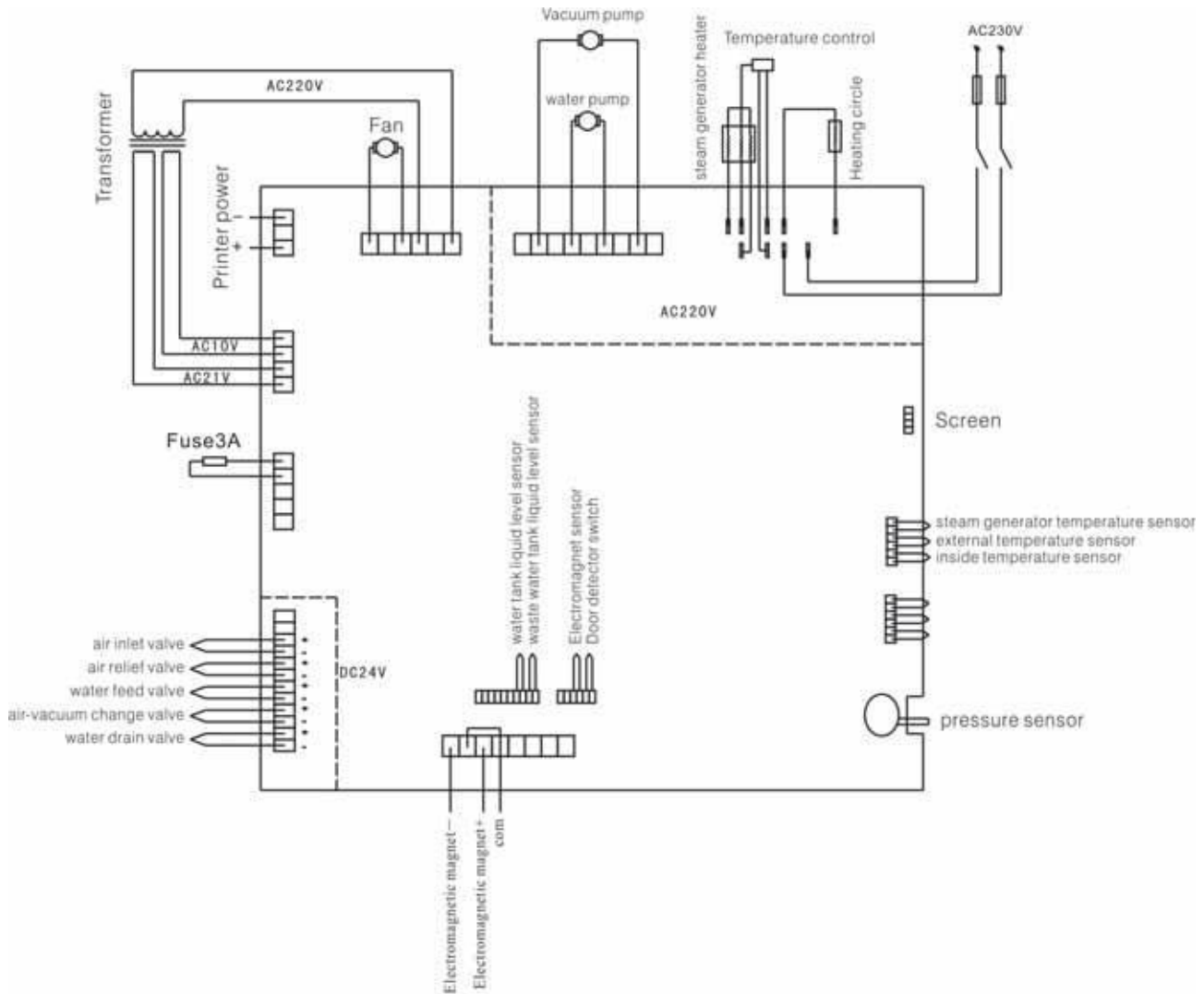

Vacuum pump power: AC: 230V 50Hz 70W
 Water pump power: AC: 230V 50Hz 47W
 Heating circle: AC: 230V 50Hz 1500W
 Heating rod: AC: 230V 50Hz 750W
 Electromagnetic valve: DC: 24V 5W

17.3 Appendix 3: EMC

Electromagnetic emissions

The Steam sterilizer is intended for use in the electromagnetic environment specified below. The customer or the user of the Steam sterilizer should assure that it is used in such an environment

Emissions test	Compliance	Electromagnetic environment – guidance
RF emissions CISPR 11	Group 1	The Steam sterilizer uses RF energy only for its internal function. Therefore, its RF emissions are very low and are not likely to cause any interference in nearby electronic equipment.
RF emissions CISPR 11	Vacuum	The Steam sterilizer is suitable for use in all establishments, including domestic establishments and those directly connected to the public low-voltage power supply network that supplies buildings used for domestic purposes.
Harmonic emissions IEC 61000-3-2	Class A	
Voltage fluctuations/ flicker emissions IEC 61000-3-3	Complies	

Electromagnetic immunity

The Steam sterilizer is intended for use in the electromagnetic environment specified below. The customer or the user of the Steam sterilizer should assure that it is used in such an environment.

Immunity test	IEC 60601 test level	Compliance level	Electromagnetic environment – guidance
Electrostatic discharge (ESD) IEC 61000-4-2	6 kV contact 8 kV air	6 kV contact 8 kV air	Floors should be wood, concrete or ceramic tile. If floors are covered with synthetic material, the relative humidity should be at least 30 %.
Electrical fast transient/burst IEC 61000-4-4	2 kV for power supply lines 1 kV for input/output lines	2 kV for power supply lines 1 kV for input/output lines	Mains power quality should be that of a typical commercial or hospital environment.
Surge IEC 61000-4-5	1 kV line(s) to line(s) 2 kV line(s) to earth	1 kV line(s) to line(s) 2 kV line(s) to earth	Mains power quality should be that of a typical commercial or hospital environment.
interruptions and voltage variations on power supply input lines IEC 61000-4-11	<5 % <i>UT</i> (>95 % dip in <i>UT</i>) for 0,5 cycle 40 % <i>UT</i> (60 % dip in <i>UT</i>) for 5 cycles 70 % <i>UT</i> (30 % dip in <i>UT</i>) for 25 cycles <5 % <i>UT</i> (>95 % dip in <i>UT</i>) for 5 sec	<5 % <i>UT</i> (>95 % dip in <i>UT</i>) for 0,5 cycle 40 % <i>UT</i> (60 % dip in <i>UT</i>) for 5 cycles 70 % <i>UT</i> (30 % dip in <i>UT</i>) for 25 cycles <5 % <i>UT</i> (>95 % dip in <i>UT</i>) for 5 sec	Mains power quality should be that of a typical commercial or hospital environment. If the user of the Steam sterilizer requires continued operation during power mains interruptions, it is recommended that the Steam sterilizer be powered from an uninterruptible power supply or a battery.
Power frequency (50/60 Hz) magnetic field IEC 61000-4-8	3 A/m	3 A/m	Power frequency magnetic fields should be at levels characteristic of a typical location in a typical commercial or hospital environment.

Electromagnetic immunity

The Steam sterilizer is intended for use in the electromagnetic environment specified below. The customer or the user of the Steam sterilizer should assure that it is used in such an environment.

Immunity test	IEC 60601 test level	Compliance level	Electromagnetic environment - guidance
Conducted RF	3 Vrms	3 Vrms	Portable and mobile RF communications equipment should be used no closer to any part of the Steam

IEC 61000-4-6	150 kHz to 80 MHz	150 kHz to 80 MHz 3 Vrms	sterilizer including cables, than the recommended separation distance calculated from the equation applicable to the frequency of the transmitter.
Radiated RF	3 V/m	3 V/m	
IEC 61000-4-3	80 MHz to 2,5 GHz	80 MHz to 2,5 GHz 3 V/m	$d = 1,2\sqrt{P}$ $d = 1,2\sqrt{P}$ 80 MHz to 800 MHz $d = 2,3\sqrt{P}$ 800 MHz to 2,5 GHz
			where P is the maximum output power rating of the transmitter in watts (W) according to the transmitter manufacturer and d is the recommended separation distance in meters (m).
			Field strengths from fixed RF transmitters, as determined by an electromagnetic site survey, a should be less than the compliance level in each frequency range
			Interference may occur in the vicinity of equipment marked with the following symbol:
			

NOTE 1 At 80 MHz and 800 MHz, the higher frequency range applies.

NOTE 2 these guidelines may not apply in all situations. Electromagnetic propagation is affected by absorption and reflection from structures, objects and people a Field strengths from fixed transmitters, such as base stations for radio (cellular/cordless) telephones and land mobile radios, amateur radio, AM and FM radio broadcast and TV broadcast cannot be predicted theoretically with accuracy. To assess the electromagnetic environment due to fixed RF transmitters, an electromagnetic site survey should be considered. If the measured field strength in the location in which the Steam sterilizer is used exceeds the applicable RF compliance level above, the Steam sterilizer should be observed to verify normal operation. If abnormal performance is observed, additional measures may be necessary, such as reorienting or relocating the Steam sterilizer. Over the frequency range 150 kHz to 80 MHz, field strengths should be less than 3 V/m

**Recommended separation distances between
Portable and mobile RF communications equipment and the Steam sterilizer**

The Steam sterilizer is intended for use in an electromagnetic environment in which radiated RF disturbances are controlled. The customer or the user of the Steam sterilizer can help prevent electromagnetic interference by maintaining a minimum distance between portable and mobile RF communications equipment (transmitters) and the Steam sterilizer as recommended below, according to the maximum output power of the communications equipment.

Rated maximum output power of transmitter W	Separation distance according to frequency of transmitter		
	150 kHz to 80 MHz	80 MHz to 800 MHz	800 MHz to 2,5 GHz
	<i>d</i> = 1,2	<i>d</i> = 1,2	<i>d</i> = 2,3
0,01	0,12	0,12	0,23
0,1	0,38	0,38	0,73
1	1,2	1,2	2,3
10	3,8	3,8	7,3
100	12	12	23

Model

Serial Number

Distributed by
