

# Manual Cutting Mill SM300



Distributed by:

**Lab Unlimited**  
CARL STUART GROUP

Tallaght Business Park  
Whitestown, Dublin 24,  
Ireland  
D24 RFK3

Tel: (01) 4523432  
Fax: (01) 4523967  
E-mail: [info@labunlimited.com](mailto:info@labunlimited.com)  
Web: [www.labunlimited.com](http://www.labunlimited.com)

Quatro House, Frimley Road,  
Camberley,  
United Kingdom  
GU16 7ER

Tel: 08452 30 40 30  
Fax: 08452 30 50 30  
E-mail: [info@labunlimited.co.uk](mailto:info@labunlimited.co.uk)  
Web: [www.labunlimited.co.uk](http://www.labunlimited.co.uk)



Translation

**Retsch**<sup>®</sup>

**Copyright**

© Copyright by  
Retsch GmbH  
Haan, Retsch-Allee 1-5  
D-42781 Haan  
Federal Republic of Germany



<b>1</b>	<b>Notes on the Operating Manual .....</b>	<b>6</b>
1.1	Explanations of the safety warnings .....	7
1.2	General safety instructions .....	8
1.3	Repairs.....	9
<b>2</b>	<b>Confirmation .....</b>	<b>10</b>
<b>3</b>	<b>Transport, scope of delivery, installation .....</b>	<b>11</b>
3.1	Packaging .....	11
3.2	Transport.....	11
3.3	Temperature fluctuations and condensed water .....	11
3.4	Conditions for the place of installation .....	11
3.5	Removing Transport Safeguards.....	12
3.6	Mounting the Feed Hopper .....	12
3.6.1	Removing the Transport Safeguard .....	12
3.6.2	Mounting the Feed Hopper .....	13
3.7	Installation of the machine .....	14
3.8	Electrical connection.....	15
3.9	Type plate description.....	15
<b>4</b>	<b>Technical data.....</b>	<b>17</b>
4.1	Use of the machine for the intended purpose.....	17
4.2	Emissions.....	18
4.3	Degree of protection .....	18
4.4	Motor rotation speed.....	18
4.5	Receptacle volume .....	18
4.6	Rated power .....	18
4.7	Dimensions and weight.....	18
4.8	Required floor space.....	18
<b>5</b>	<b>Operating the machine .....</b>	<b>19</b>
5.1	Views of the Instrument .....	19
5.2	Operating elements and displays .....	21
5.3	Overview table of the parts of the device .....	22
5.4	Opening and closing of the grinding chamber.....	23
5.5	Mounting the bottom sieve.....	23
5.6	Replacing the rotor .....	24
5.6.1	Removing the Rotor .....	25
5.6.2	Inserting the Rotor .....	26
5.7	Inserting the filter unit and collecting receptacle.....	26
5.8	Starting the grinding process.....	27
5.9	Stopping the grinding process .....	27
<b>6</b>	<b>Mode of Operation of Feed Hopper .....</b>	<b>28</b>
<b>7</b>	<b>Assembling and using the cyclone .....</b>	<b>29</b>
7.1	Cyclone assembly.....	29
7.1.1	Inserting the wide mouth bottle adapter .....	33
<b>8</b>	<b>Cleaning and service .....</b>	<b>34</b>
8.1	Adjusting the cutting bars .....	34
<b>9</b>	<b>Fault messages.....</b>	<b>37</b>

10 Disposal.....38  
11 Index .....39  
Appendix ..... following page

## 1 Notes on the Operating Manual

This operating manual is a technical guide on how to operate the device safely and it contains all the information required for the areas specified in the table of contents. This technical documentation is a reference and instruction manual. The individual chapters are complete in themselves.

Familiarity (of the respective target groups defined according to area) with the relevant chapters is a precondition for the safe and appropriate use of the device.

This operating manual does not contain any repair instructions. If faults arise or repairs are necessary, please contact your supplier or get in touch with Retsch GmbH directly.

Application technology information relating to samples to be processed is not included but can be read on the Internet on the respective device's page at [www.retsch.com](http://www.retsch.com).

### **Changes**

Subject to technical changes.

### **Copyright**

Disclosure or reproduction of this documentation, use and disclosure of its contents are only permitted with the express permission of Retsch GmbH.

Infringements will result in damage compensation liability.

## 1.1 Explanations of the safety warnings

In this Operating Manual we give you the following safety warnings

---

**Serious injury** may result from failing to heed these safety warnings. We give you the following warnings and corresponding content.

---

 **WARNING**

**Type of danger / personal injury**

Source of danger

- Possible consequences if the dangers are not observed.
  - **Instructions on how the dangers are to be avoided.**
- 

We also use the following signal word box in the text or in the instructions on action to be taken:

 **WARNING**

---

**Moderate or mild injury** may result from failing to heed these safety warnings. We give you the following warnings and corresponding content.

---

 **CAUTION**

**Type of danger / personal injury**

Source of danger

- Possible consequences if the dangers are not observed.
  - **Instructions on how the dangers are to be avoided.**
- 

We also use the following signal word box in the text or in the instructions on action to be taken:

 **CAUTION**

---

In the event of possible **property damage** we inform you with the word "Instructions" and the corresponding content.

---

*NOTICE*

**Nature of the property damage**

Source of property damage

- Possible consequences if the instructions are not observed.
  - **Instructions on how the dangers are to be avoided.**
- 

We also use the following signal word in the text or in the instructions on action to be taken:

*NOTICE*

## 1.2 General safety instructions

---

 **CAUTION**

### Read the Operating Manual

Non-observance of these operating instructions

- The non-observance of these operating instructions can result in personal injuries.
- **Read the operating manual before using the device.**
- **We use the adjacent symbol to draw attention to the necessity of knowing the contents of this operating manual.**



---

**Target group :** All persons concerned with the machine in any form

This machine is a modern, high performance product from Retsch GmbH and complies with the state of the art. Operational safety is given if the machine is handled for the intended purpose and attention is given to this technical documentation.

You, as the owner/managing operator of the machine, must ensure that the people entrusted with working on the machine:

- have noted and understood all the regulations regarding safety,
- are familiar before starting work with all the operating instructions and specifications for the target group relevant for them,
- have easy access always to the technical documentation for this machine,
- and that new personnel before starting work on the machine are familiarised with the safe handling of the machine and its use for its intended purpose, either by verbal instructions from a competent person and/or by means of this technical documentation.

Improper operation can result in personal injuries and material damage. You are responsible for your own safety and that of your employees.

Make sure that no unauthorised person has access to the machine.

---

 **CAUTION**

### Changes to the machine

- Changes to the machine may lead to personal injury.
- **Do not make any change to the machine and use spare parts and accessories that have been approved by Retsch exclusively.**

---

### NOTICE

#### Changes to the machine

- The conformity declared by Retsch with the European Directives will lose its validity.
  - You lose all warranty claims.
  - **Do not make any change to the machine and use spare parts and accessories that have been approved by Retsch exclusively.**
-



### 1.3 Repairs

This operating manual does not contain any repair instructions. For your own safety, repairs may only be carried out by Retsch GmbH or an authorized representative or by Retsch service engineers.

**In that case please inform:**

The Retsch representative in your country
Your supplier
Retsch GmbH directly

**Your Service Address:**

--

## 2 Confirmation

This operating manual contains essential instructions for operating and maintaining the device which must be strictly observed. It is essential that they be read by the operator and by the qualified staff responsible for the device before the device is commissioned. This operating manual must be available and accessible at the place of use at all times.

The user of the device herewith confirms to the managing operator (owner) that (s)he has received sufficient instructions about the operation and maintenance of the system. The user has received the operating manual, has read and taken note of its contents and consequently has all the information required for safe operation and is sufficiently familiar with the device.

As the owner/managing operator you should for your own protection have your employees confirm that they have received the instructions about the operation of the machine.

I have read and taken note of the contents of all chapters in this operating manual as well as all safety instructions and warnings.

### User

Surname, first name (block letters)

Position in the company

Signature

### Service technician or operator

Surname, first name (block letters)

Position in the company

Place, date and signature

### 3 Transport, scope of delivery, installation

#### 3.1 Packaging

The packaging has been adapted to the mode of transport. It complies with the generally applicable packaging guidelines.

---

##### *NOTICE*

###### **Storage of packaging**

- In the event of a complaint or return, your warranty claims may be endangered if the packaging is inadequate or the machine has not been secured correctly.
  - **Please keep the packaging for the duration of the warranty period.**
- 

#### 3.2 Transport

##### *NOTICE*

###### **Transport**

- Mechanical or electronic components may be damaged.
  - **The machine may not be knocked, shaken or thrown during transport.**
- 

#### 3.3 Temperature fluctuations and condensed water

##### *NOTICE*

###### **Temperature fluctuations**

The machine may be subject to strong temperature fluctuations during transport (e.g. aircraft transport)

- The resultant condensed water may damage electronic components.
  - **Protect the machine from condensed water.**
- 

#### 3.4 Conditions for the place of installation

Ambient temperature: 5°C to 40°C

---

##### *NOTICE*

###### **Ambient temperature**

- Electronic and mechanical components may be damaged and the performance data alter to an unknown extent.
  - **Do not exceed or fall below the permitted temperature range of the machine (5°C to 40°C / ambient temperature).**
- 

Atmospheric humidity:

Maximum relative humidity 80% at temperatures up to 31°C, decreasing linearly up to 50% relative humidity at 40°C

---

*NOTICE*

**Atmospheric humidity**

- Electronic and mechanical components may be damaged and the performance data alter to an unknown extent.
  - **Do not exceed the admissible range for atmospheric humidity.**
- 

### 3.5 Removing Transport Safeguards

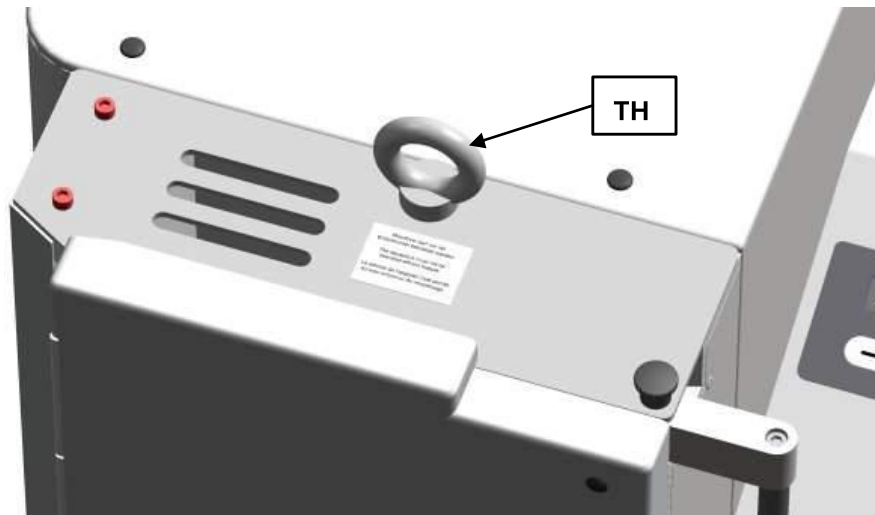

Fig. 1: Removing Transport Aid

Lift the device only by the transport aid (TH). The weight of the device is approx. 160 kg. Choose a safe lifting sling that is approved for this weight.

Keep the eye bolt (TH) for transport again at a later date.

The eye bolt must be removed before the hopper is assembled.

### 3.6 Mounting the Feed Hopper

---

 **WARNING**

1.W0004

**Risk of injury to skin and hands**

Fast rotating cutting blade

- There is a risk of injuring hands, fingers and skin.
  - **Never operate the device without a feed hopper.**
- 

*NOTICE*

**Transport safeguard**

- Components may be damaged.
  - **Operate the machine only without the transport safeguard or transport the machine only with transport safeguard.**
- 

#### 3.6.1 Removing the Transport Safeguard

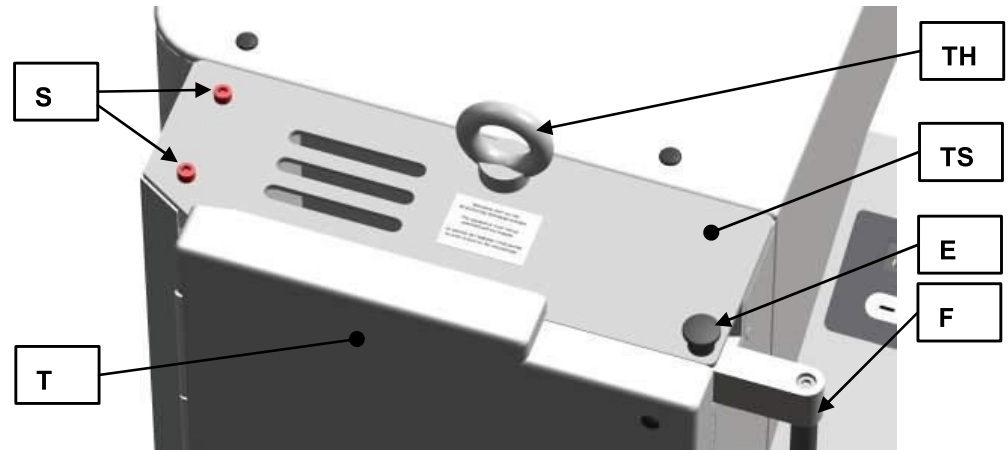

Fig. 2: Removing the Transport Safeguard

- Remove the transport aid (TH).
- Unlock the grinding chamber door by pulling the mini detent pin (E) upwards and pressing the handle of the door latch (F) backwards.
- Open the grinding chamber door (T).
- Remove the two locking screws (S).

**NOTE**

Keep the transport safeguard (TS) for transport at a later date.

**3.6.2 Mounting the Feed Hopper**

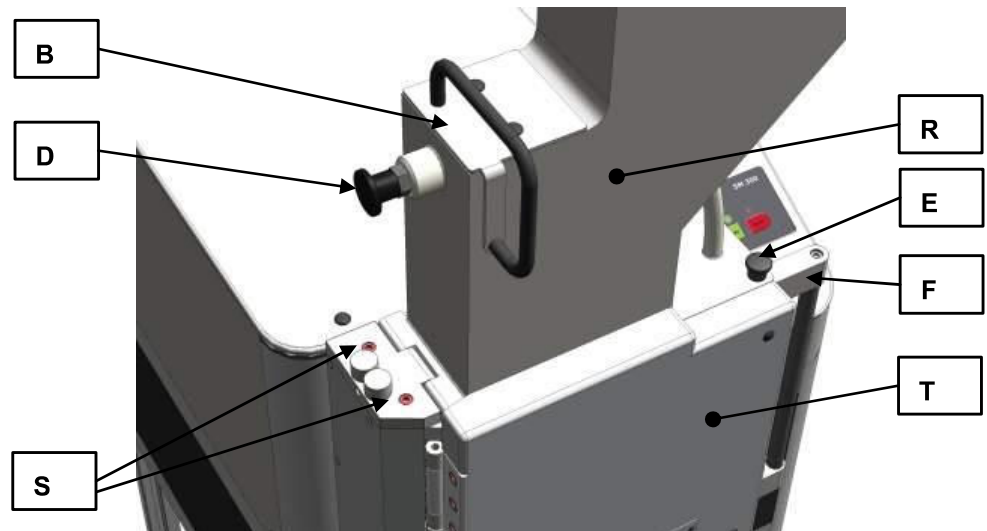

Fig. 3: Mounting the Feed Hopper

- Push the handle on the door latch (F) backwards.
- Open the grinding chamber door (T).
- Pull the plunger (B) into the upper latching position.
- Place the feed hopper (R) on the device. (see diagram)

**CAUTION**

Until the feed hopper (R) is secured by the two socket-head screws, there is a risk of it falling out of the device.

- Release the detent pin bolt (D) on the plunger (B).
- Push the plunger downwards.

- Screw the two provided socket-head screws (S) through the hinge on the feed hopper into the enclosure.
- At first, tighten the screws only slightly.
- Close the grinding chamber door.
- Pull the handle on the door catch (F) forwards until the mini detent pin (E) engages.
- Adjust the feed hopper until the plunger can be moved upwards and downwards easily without jamming.
- Tighten the two socket-head screws securely. (10Nm)
- Check again if the plunger moves upwards and downwards easily without jamming.
- Put the two protective caps (SK) onto the screws (S).

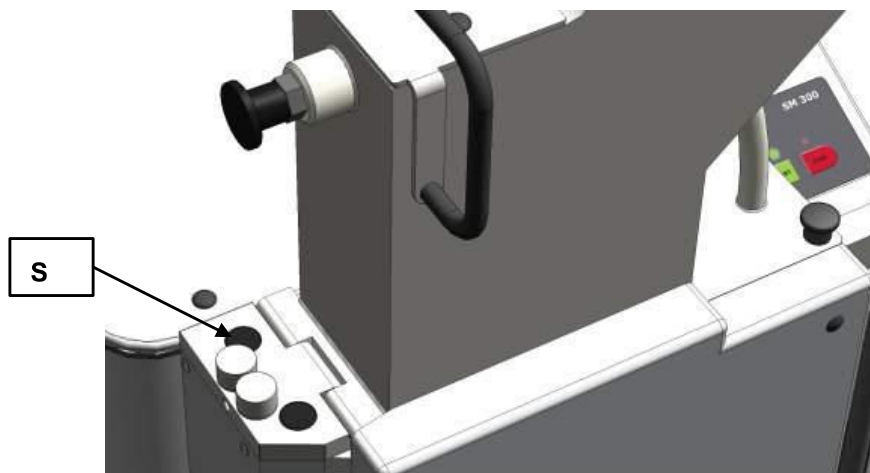

Fig. 4: Putting on the Protective Caps

*NOTE*

When new, the grinding chamber door and the handle on the door latch are somewhat difficult to move.

### 3.7 Installation of the machine

Installation height: maximum 2000 m above sea level

*NOTE*

**Installation**

- Depending on the operating status of the mill, there may be slight vibrations.
- **Place the mill on an even, flat and balanced supporting surface only. The supporting surface must be stable and must not vibrate.**

*NOTICE*

**Installation of the machine**

- It must be possible to disconnect the machine from the mains at any time.
- **Install the machine such that the connection for the mains cable is easily accessible.**

### 3.8 Electrical connection

**⚠ WARNING**

When connecting the power cable to the mains supply, use an external fuse that complies with the regulations applicable to the place of installation .

- Please check the type plate for details on the necessary voltage and frequency for the device.
- Make sure the levels agree with the existing mains power supply.
- Use the supplied connection cable to connect the device to the mains power supply.

**NOTICE**

**Electrical connection**

- Mechanical or electronic components may be damaged.
- **Please observe the information on the type plate.**

### 3.9 Type plate description

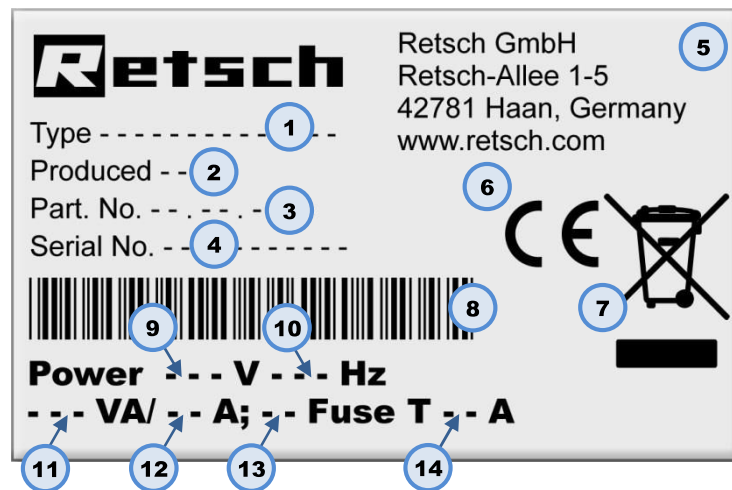

Fig. 5: Type plate lettering

- 1 Device designation
- 2 Year of production
- 3 Part number
- 4 Serial number
- 5 Manufacturer's address
- 6 CE marking
- 7 Disposal label
- 8 Bar code
- 9 Power version
- 10 Mains frequency
- 11 Capacity
- 12 Amperage
- 13 Number of fuses
- 14 Fuse type and fuse strength

In the case of questions please provide the device designation (1) or the part number (3) and the serial number (4) of the device.



## 4 Technical data

### 4.1 Use of the machine for the intended purpose

**Target group:** Users, managing operators (owners)

**Machine type designation:** SM 300

The heavy-duty SM 300 cutting mill serves to grind flexible, hard-ductile and fibrous products and product mixtures in batches or continuously. The SM 300 is not designed for grinding wet or moist materials. The special shape of the cutting tools in conjunction with the drive enable fast, efficient grinding without adversely affecting the material being processed.

The following are the special characteristics

The new heavy-duty SM 300 cutting mill is convincing in difficult size reduction tasks where other cutting mills fail. The high torque of the new 3 KW drive with additional auxiliary flywheel mass allows a particularly effective preliminary size reduction of heterogeneous material mixes, such as waste or electronic components. Analytical fineness is usually attained in one step. The cutting mill is used successfully for a great variety of other materials also, whereby the grinding stock is warmed up only to a low degree during the grinding process so that the mill is also suitable for grinding temperature-sensitive materials.

A further innovation is the cutting mill's broad, freely selectable speed range from 700 to 3,000 rpm. The large selection of sieves, hoppers and collecting vessels allow the mill to be adapted to individual tasks.

- fast, gradual size reduction by 18 cutting plates spaced in a helical pattern along the circumference of the rotor
- parallel section rotor
- cutting tools which are made of high-quality materials and can be reused over and over again
- high level of operating convenience due to central lock and operator panel
- consistent operational reliability in all user-relevant equipment components
- versatility in use due to variant designs and a large number of accessories
- powerful size reduction thanks to the 3-KW motor's high torque
- perfect adaptation to the material being ground thanks to the variable speed from 700 to 3,000 rpm
- optimised cutting effect due to the double-acting cutting bars
- very fast cleaning thanks to hinged enclosure with smooth surfaces and push-fit rotor
- defined final fineness due to bottom sieves with aperture sizes 0.25 - 20 mm

---

#### NOTICE

##### Area of use of the machine

- This machine is a laboratory machine designed for 8-hour single-shift operation.
  - **This machine may not be used as a production machine nor is it intended for continuous operation.**
-

## 4.2 Emissions



### Damage to hearing

The level of noise can be high depending on the type of material, the knife used, the speed set and the duration of the grinding process.

- Noise that is excessive in terms of level and duration can cause impaired or permanently damaged hearing.

- **Ensure suitable sound-proofing measures or wear hearing protection.**



Noise measurement according to DIN 45635-31-01-KL3.

Emissions at 1-m spacing:

approx. 66 dB (A) at idle speed

During size reduction depending on the sample:

approx. 75 to 92 dB (A) with peaks up to 98 dB (A)

## 4.3 Degree of protection

- IP20

## 4.4 Motor rotation speed

The motor speed is 700 - 3000 min<sup>-1</sup> and can be adjusted in increments of 100 min<sup>-1</sup>.

## 4.5 Receptacle volume

The capacity is < 5 l.

## 4.6 Rated power

- 200-240 V: 3000W, 16A

## 4.7 Dimensions and weight

When closed: (including base frame and standard hopper)

Height: 1691 mm

Width: 795 - 1090 mm

Depth: 765 mm

Weight: approx. 160 kg

## 4.8 Required floor space

1090 mm x 765 mm - no safety spacing needed

## 5 Operating the machine

### 5.1 Views of the Instrument

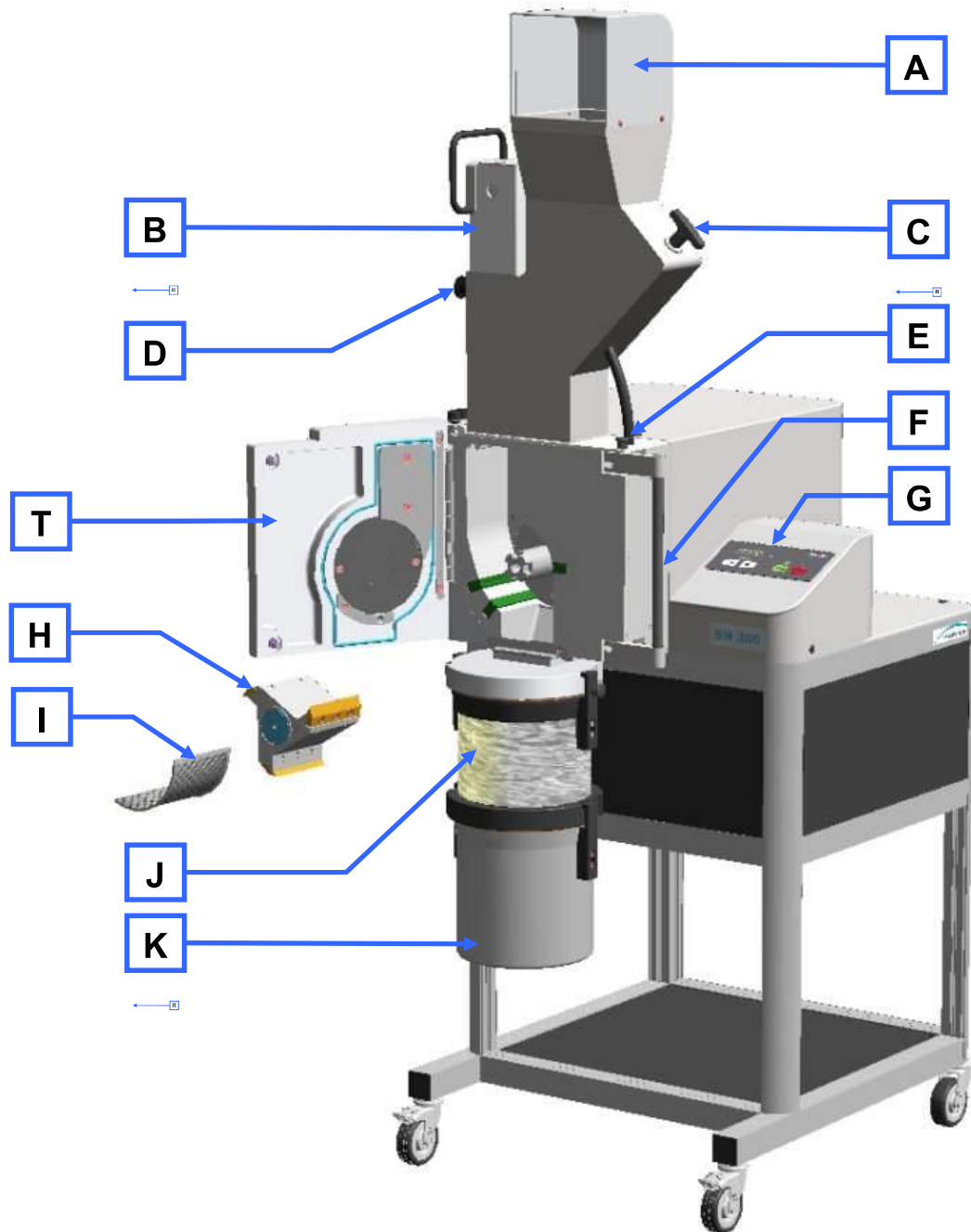

Fig. 6: Front view

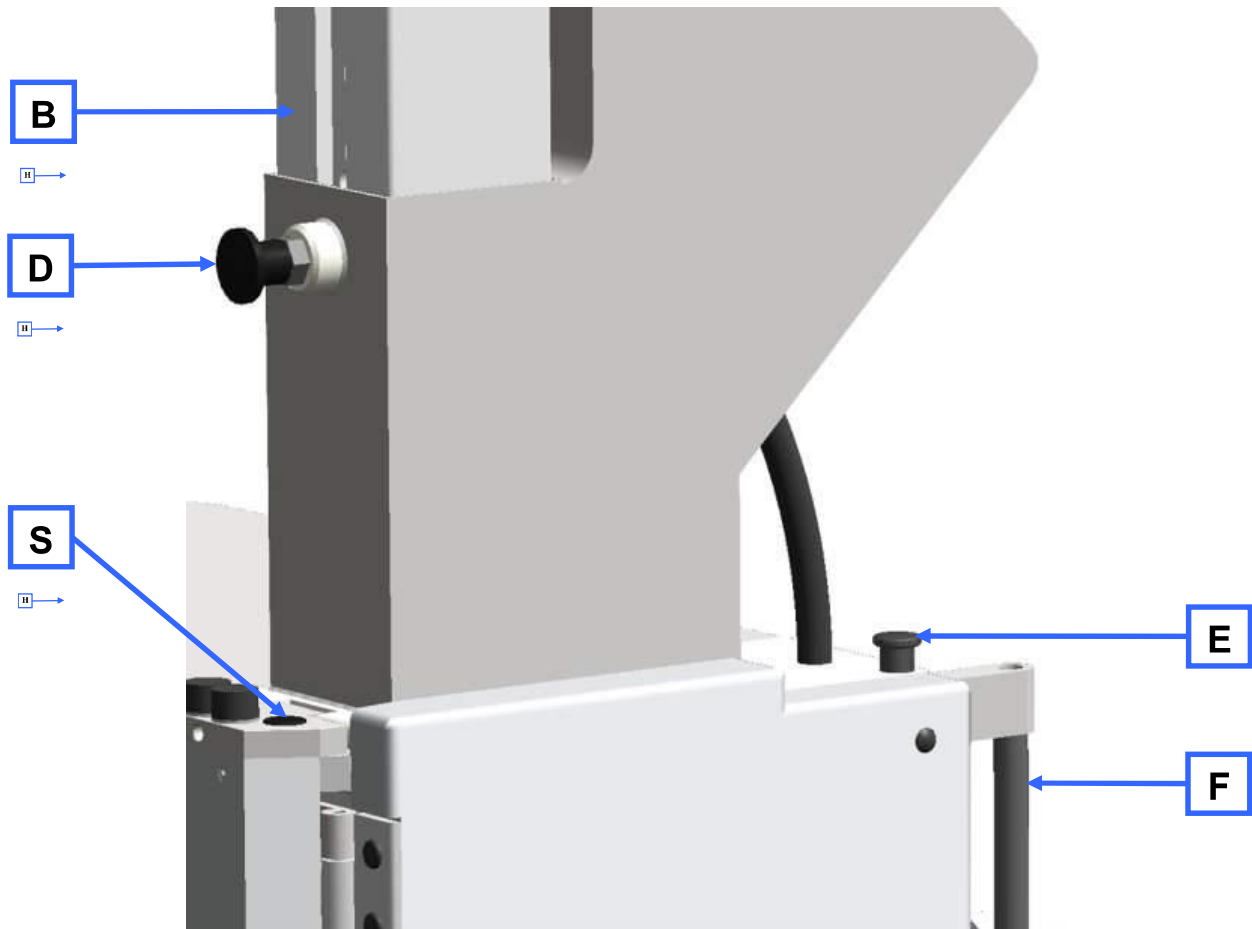

Fig. 7: Front view from the left (detail)



Fig. 8: Rear view

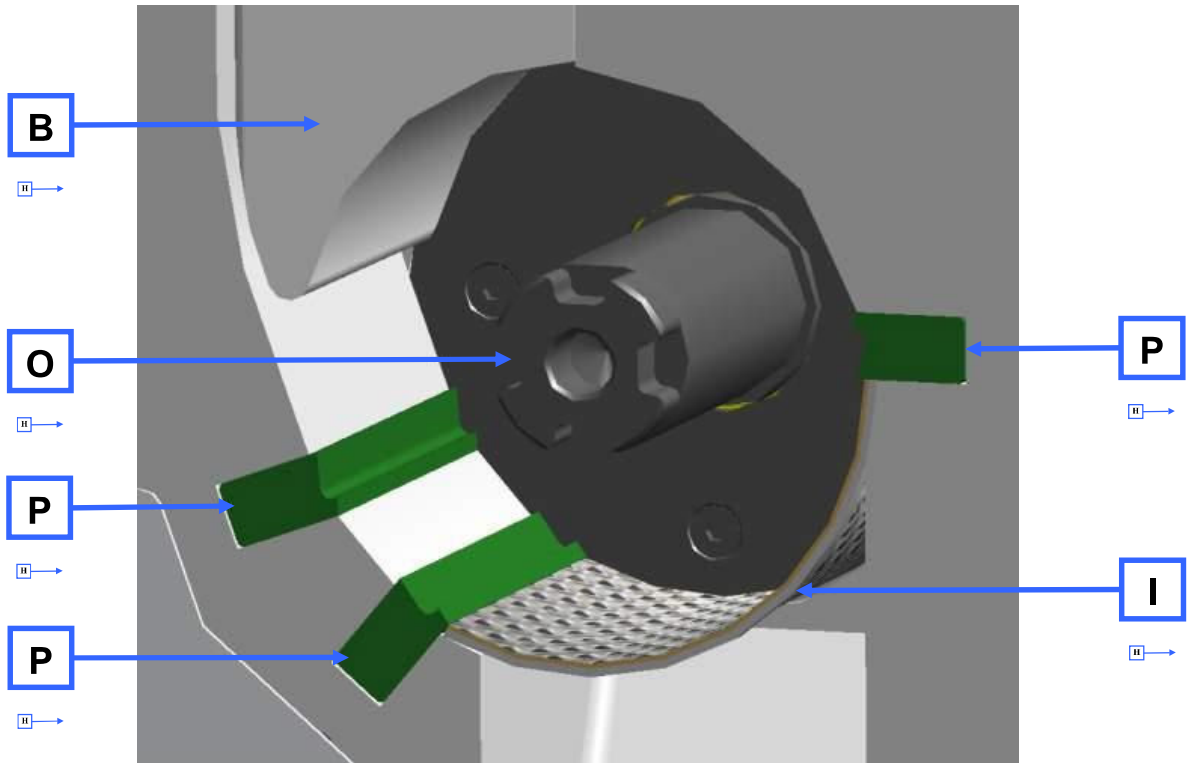

Fig. 9: View of grinding chamber

## 5.2 Operating elements and displays

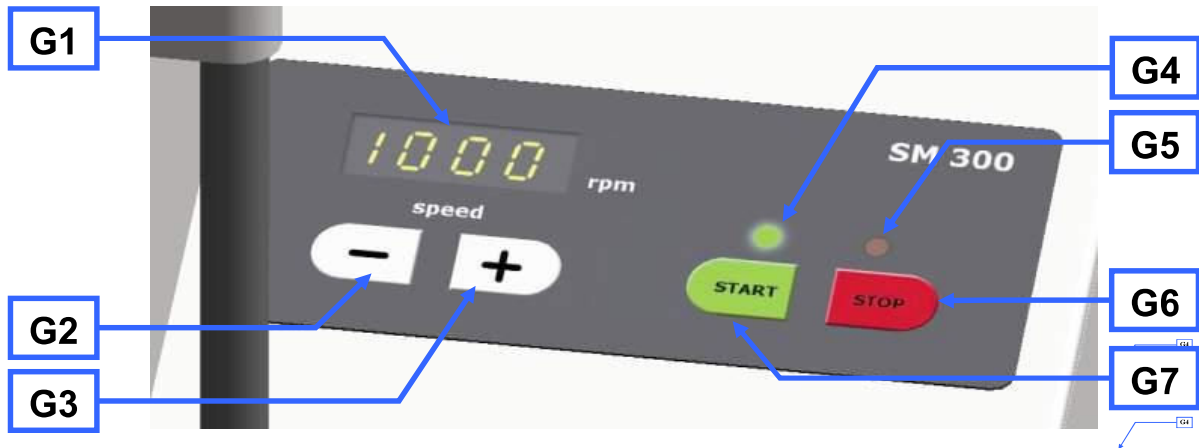

Fig. 10: View of the control panel and the display

### 5.3 Overview table of the parts of the device

Element	Description	Function
<b>A</b>	Safety guard for the feed hopper	Prevents contact with the feed hopper
<b>B</b>	Plunger	Releases the material feed chute in pulled state. Pushes grinding material onto the rotor.
<b>C</b>	Metering plunger	Pushes the grinding material into the feed chute area of the fill plunger <ul style="list-style-type: none"> <li>– Extended: grinding material can be loaded.</li> <li>– Inserted: grinding material remains in the area of the fill plunger.</li> </ul>
<b>D</b>	Locking pin	Prevents, blocks or releases the fill plunger. <ul style="list-style-type: none"> <li>– Extended: free movement of the fill plunger is possible</li> <li>– Released: fill plunger engages in the uppermost position</li> </ul>
<b>E</b>	Mini locking pin	Engages the door lock
<b>F</b>	Door lock grip	Enables the door to be opened
<b>G</b>	Control panel	Starts and stops the device, adjusts the speed
<b>H</b>	Parallel section rotor	Grinding tool
<b>I</b>	Bottom sieve	Influences the ultimate fineness of the grinding material through the size and type of perforation
<b>J</b>	Ring filter	Air outlet and filter for material to be ground
<b>K</b>	Collecting receiver	Collects ground material
<b>L</b>	On/off switch (main switch)	Disconnects and connects the device to the mains. <ul style="list-style-type: none"> <li>– ON = LED (red) STOP lights up</li> <li>– OFF = all LEDs are extinguished</li> </ul>
<b>M</b>	16A socket	Power supply
<b>N</b>	Housing fan	Cools the housing area
<b>O</b>	Rotor shaft	Accommodates the grinding tool
<b>P</b>	Cutting bars	Counterpart to grinding tool
<b>R</b>	Feed hopper	Feeding the grinding material
<b>S</b>	Feed hopper fixing screws	Safety bolts for the feed hopper
<b>T</b>	Grinding area door	Closes the grinding area

## 5.4 Opening and closing of the grinding chamber

The motor must come to a complete stop before the mill housing can be opened.

- Stop the device by pressing the STOP button (G6).
- Pull the mini detent pin (E) upwards.
- Press the handle on the door catch (F) backwards.
- Press the door lock (F1) upwards and open the grinding chamber door.

*NOTE*

**Do not close the grinding chamber door if the feed hopper is folded out to the side.** That would damage the device.

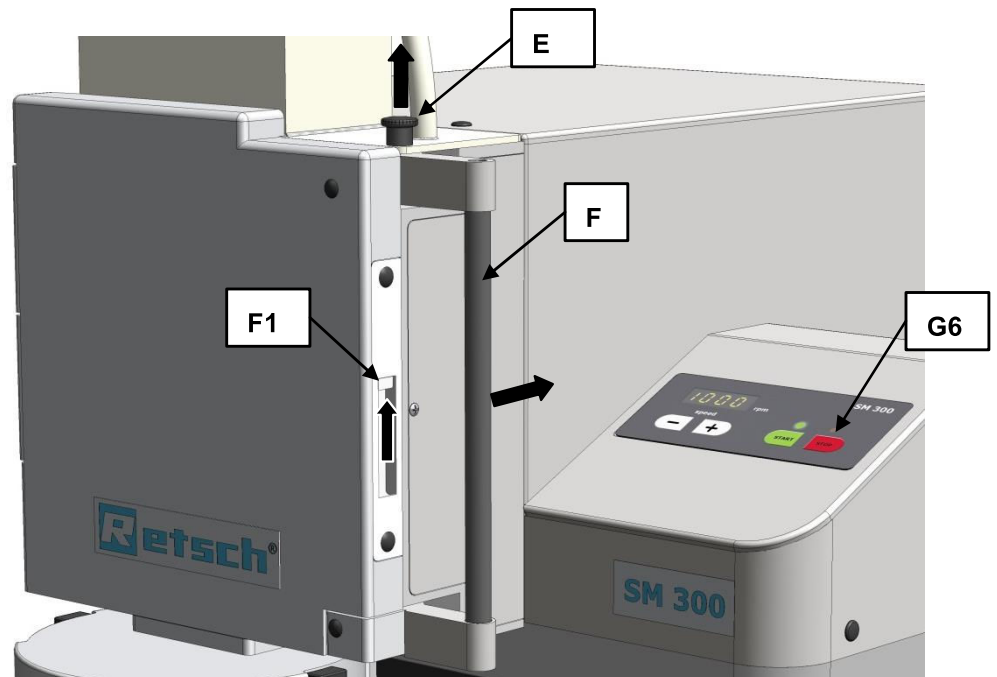

Fig. 11: Opening the grinding chamber door

## 5.5 Mounting the bottom sieve

- Select the appropriate bottom sieve.
- Open the mill housing and slide the bottom sieve (I) of your choice into the device.

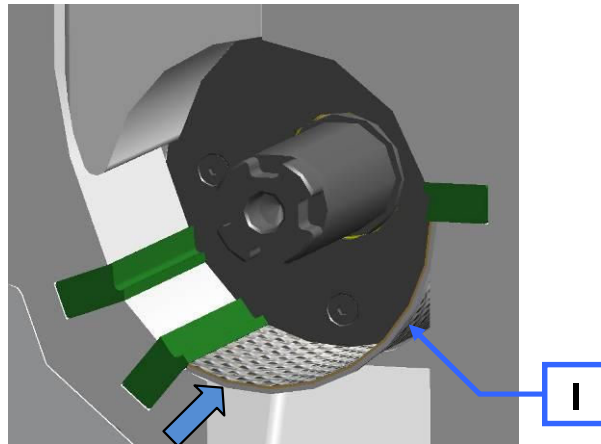

Fig. 12: Inserting the bottom sieve

## 5.6 Replacing the rotor

**CAUTION**

**Injuries in the form of cuts**

Sharp cutting edges on the rotors and cutting bars

- The sharp cutting edges on the rotors and cutting bars can injure hands.
- **Wear protective gloves when replacing the cutting rotors and cleaning the grinding chamber.**
- **Use the rotor extraction tool when handling the cutting rotors.**

**NOTE**

**Reduction of tool service life**

Abrasive sample materials

- The presence of abrasive composite materials during grinding can considerably reduce tool service life.
- **When grinding electronic scrap, take the properties of the composite materials into account.**

**NOTE**

**Damage to mechanical components**

Blockages typical of cutting mills

- When coarse, solid material is fed in for grinding, the high feeding capacity of the standard rotor can cause blockages that are typical of the cutting mills.
- **If blockages occur, switch off the mill immediately and remove the clogging material.**

**NB**

It is necessary to check whether the cutting gap is larger than 0.3 mm before each grinding operation using the parallel section rotor.

- Open the grinding area door.
- Pull the rotor (H) approx. 10 mm out of the grinding area until it can be freely rotated.

H0055



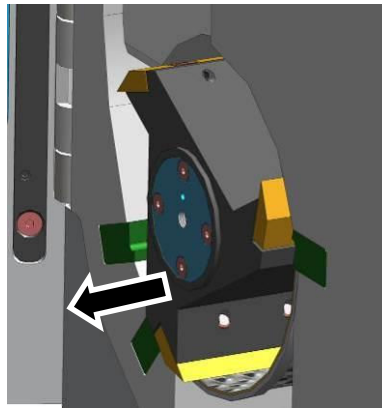

Fig. 2: Freely rotate the rotor

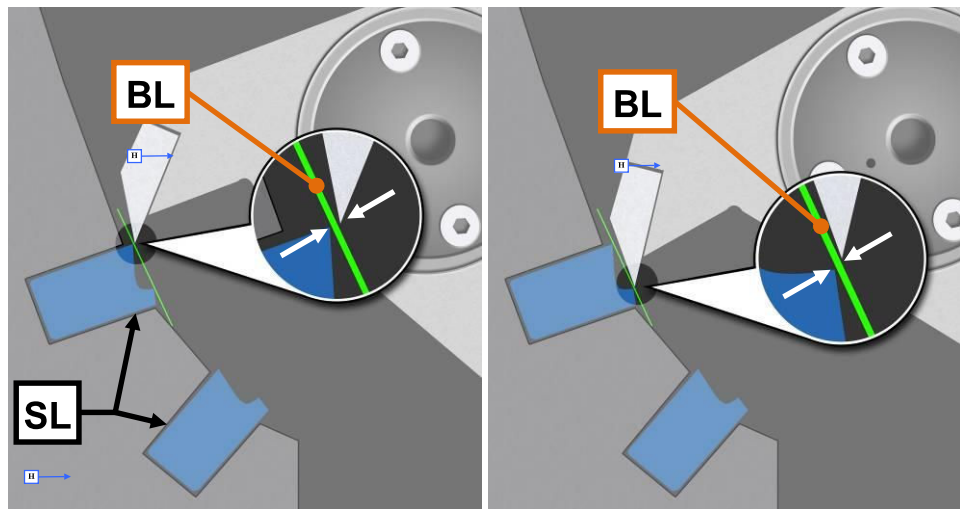

Fig. 3: Checking the cutting gap

- Using a feeler gauge (BL), check the cutting gap of all **three** cutting bars (SL). It should be at least 0.3mm.

The feeler gauge (BL) must be placed on both cut areas as shown in the diagram. The cutting gap must show a uniform distance across its entire depth. For this reason check the cutting gap across its entire depth.

The cutting edge that has the smallest distance to the knife denotes the cutting gap (SP1/2). The second cutting edge can have a larger cutting gap width.

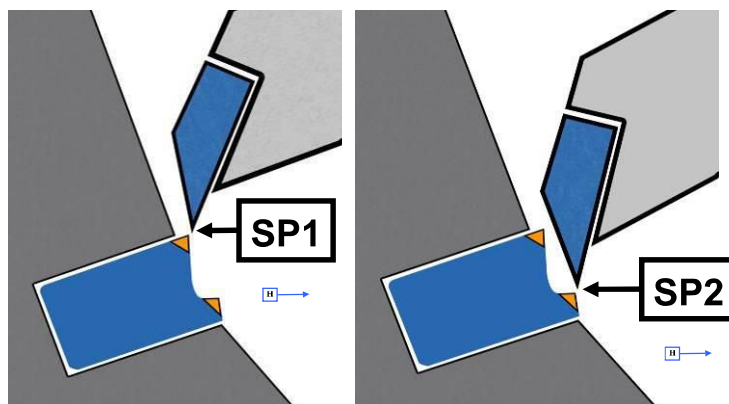

Fig. 413: Cutting gap

### 5.6.1 Removing the Rotor

- Stop the device.

- Open the grinding area door.
- Screw the removal grip (EG) onto the rotor and pull the rotor from the drive shaft.

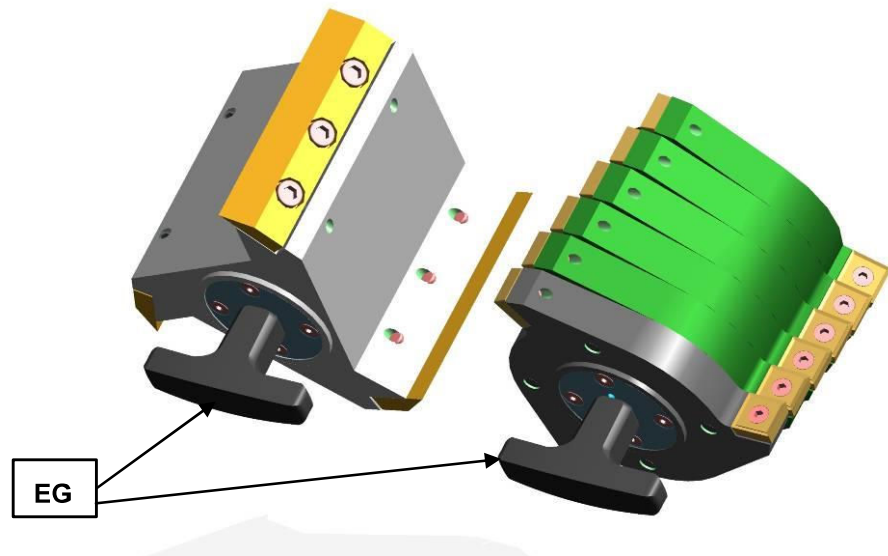

Fig 5: Removal grip

### 5.6.2 Inserting the Rotor

- Clean and lubricate the motor shaft and the rotor.
- Slide the rotor onto the motor shaft.

Apart from this the device is largely maintenance-free.

Nevertheless we recommend that the cutting tools are checked at least once a month depending on the frequency of use.

### 5.7 Inserting the filter unit and collecting receptacle

The ring sieve serves as an air outlet for the air flow that is generated by the size reduction rotors.

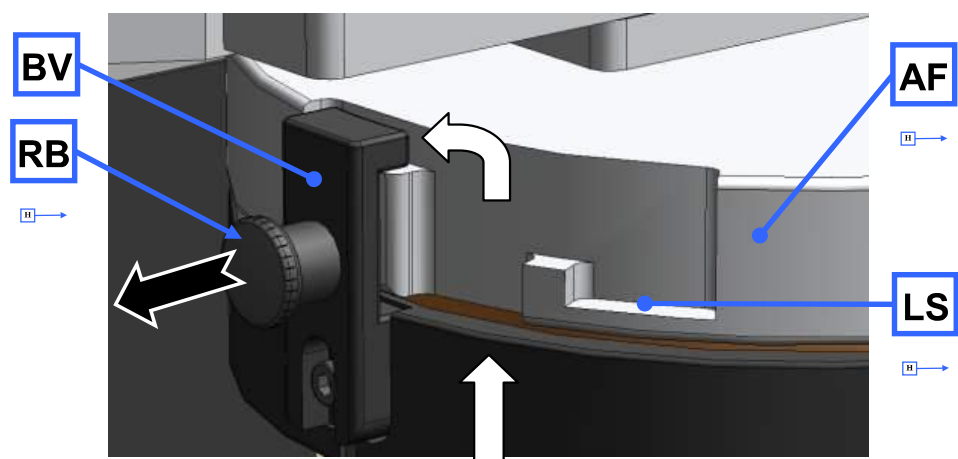

Fig. 14: Mounting and Removing the Ring Sieve

- Insert the bayonet fixing (BV) on the ring sieve (J) into the discharge flange (AF), as shown in the illustration.
- Turn the ring sieve in a clockwise direction so that the bayonet fixing will engage.

- To remove the ring sieve, pull out the latching bolt (RB) to release the bayonet fixing (BV).

Alternatively, the collecting receptacle can be positioned directly on the discharge flange. In the latching position (BV) the exit of the air flow is prevented.

In the latching position (LS) a gap remains between the discharge flange and the collecting receptacle which allows air to exit.

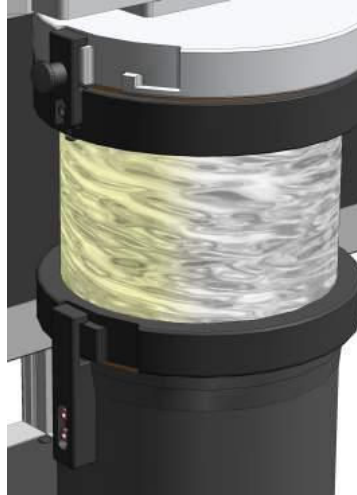

Fig. 15: Collecting Receptacle and Ring Sieve

## 5.8 Starting the grinding process

- Switch the device on.
- Set the rotation speed.
- Press the START button.

### NOTE

#### Motor blockage

The material being ground clogs the rotor

- Blockages can damage mechanical components.
- Feed material only while the device is running.
- Dose the material feed to suit the properties of the material.

## 5.9 Stopping the grinding process

The current grinding process can be cancelled by pressing the STOP button (G6).

Once the motor has come to a complete stop, you can pull the mini detent pin (E) upwards and press the handle on the door latch (F) backwards.

The grinding chamber door can be opened now.

## 6 Mode of Operation of Feed Hopper

---

### *NOTE*

#### **Motor blockage**

The material being ground clogs the rotor

- Blockages can damage mechanical components.
  - **Feed material only while the device is running.**
  - **Dose the material feed to suit the properties of the material.**
- 

- Switch the device on.
- Pull the metering plunger (C) and the plunger (B) upwards.
- Put the material to be ground into the filling hole (AE).
- If necessary, use the metering plunger to push the material in further.
- Seize the plunger by the grip and pull the detent pin (D).
- Press the plunger slowly downwards.

### *NOTE*

Do not use excessive force on the plunger. **Blockages can damage mechanical components.**

In most cases the plunger's own weight is sufficient to press the material into the grinding chamber.

If not, the plunger can be used to push the material in further carefully and within the scope of the device's efficiency

## 7 Assembling and using the cyclone

### 7.1 Cyclone assembly

 **CAUTION**

V0014

**Injuries to limbs**  
Rotating blade

- Can cause injury to hands and feet.
- **Keep hands and feet away from the device openings when the device is switched on.**
- **Pull the plug out before cleaning or retrofitting.**



 **CAUTION**

V0001

**Risk of injury to fingers**  
Reaching into the turning rotor

- Unintended reaching into the grinding area and the turning rotor.
- **Never connect the device to the mains without the discharge flange.**
- **Only operate the device with discharge flange.**

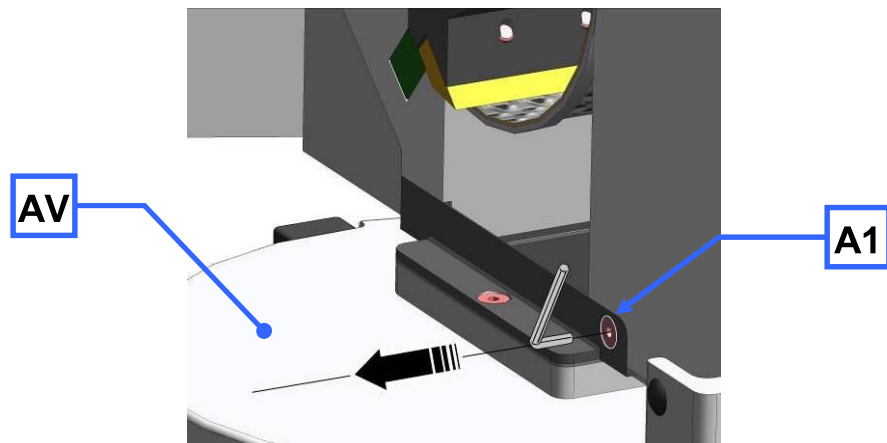

Fig. 16: Removing the discharge flange

- Disconnect the device from the mains.
- Loosen the screw (**A1**).
- Pull off the discharge flange (**AV**).

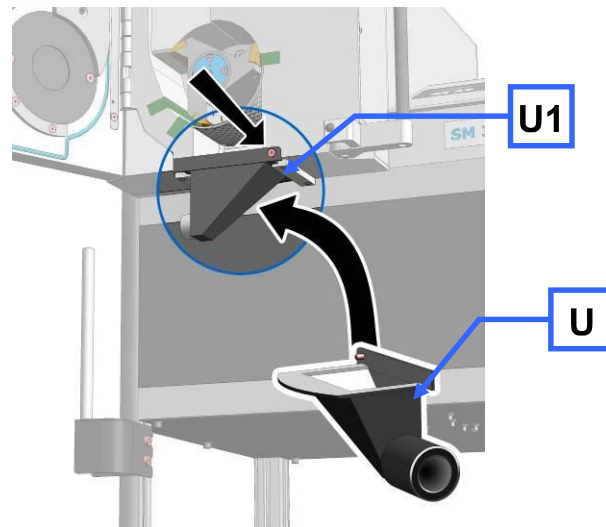

Fig. 17: Fastening the discharge flange

- Insert the retrofit dust removal (U).
- Tighten the screw (U1).

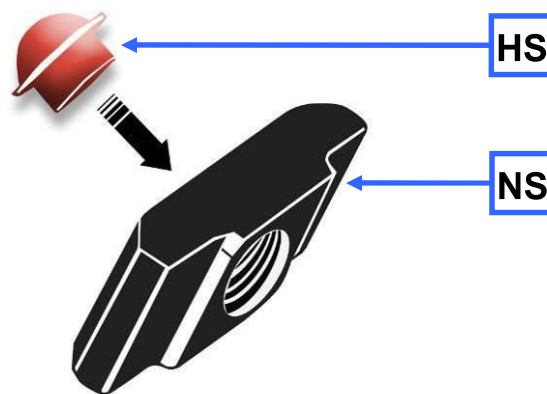

Fig. 18: Inserting the plug for the sliding block

- Insert the plug (HS) into the back (flat surface) of the sliding block (NS).

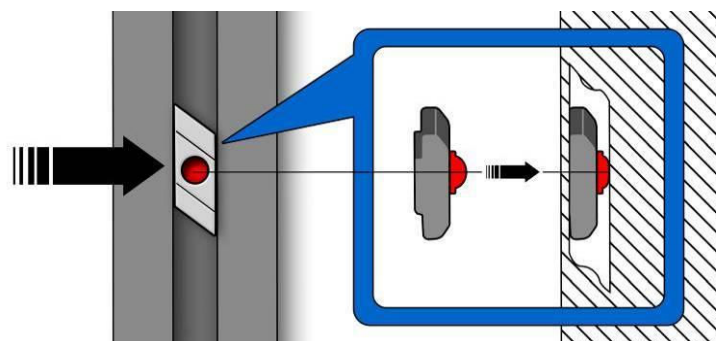

Fig. 19: Inserting the sliding block

- Guide the sliding block with plug into the aluminium profile.

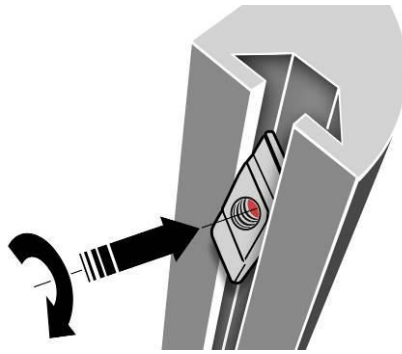

Fig. 20: Turning the sliding block

- Push in the sliding block against the resistance of the plug and turn the sliding block to the position indicated.
- Insert the second sliding block in the same way.

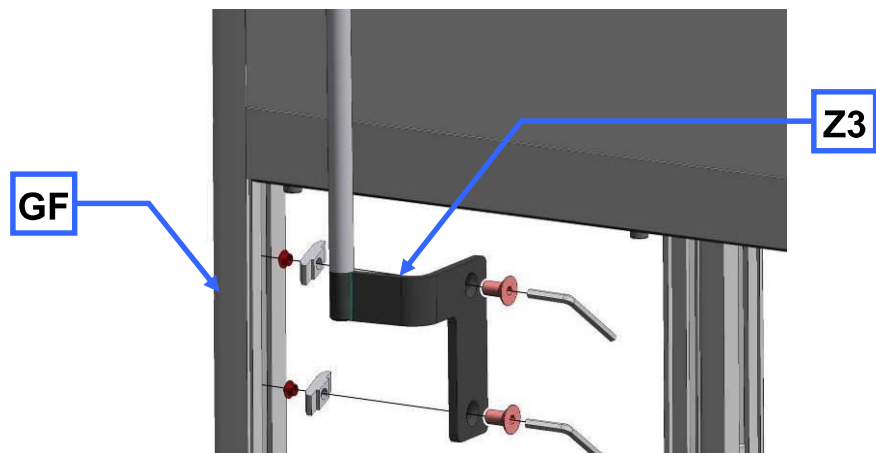

Fig. 21: Fastening the cyclone support

- Fasten the cyclone support (**Z3**) on the front left-hand leg of the housing (**GF**).

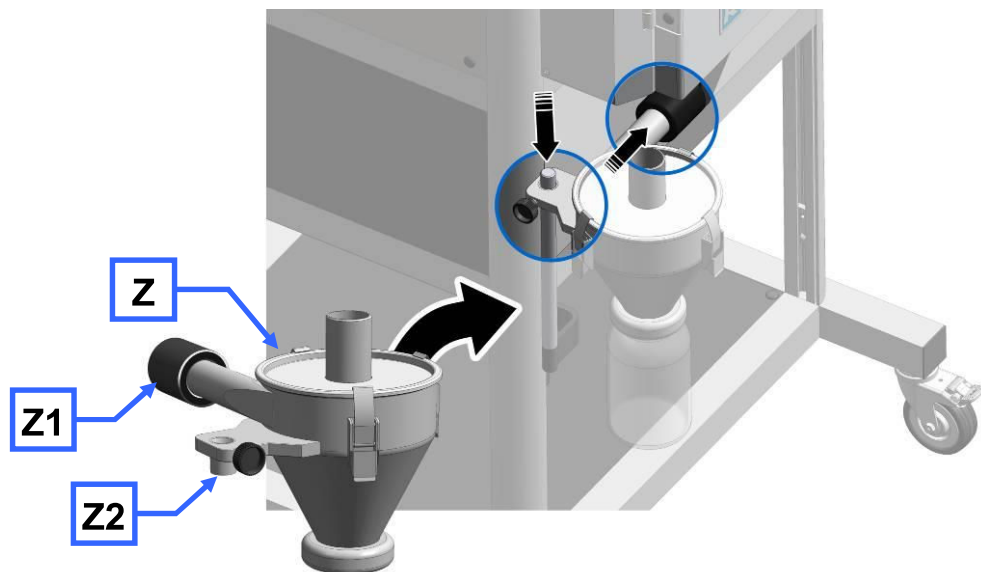

Fig. 22: Installing the cyclone

- Connect the cyclone (**Z2**) onto the rod of the stand on the cyclone support.
- Turn the side tube to the discharge flange and push the coupling (**Z1**) onto the adapters on the discharge flange.

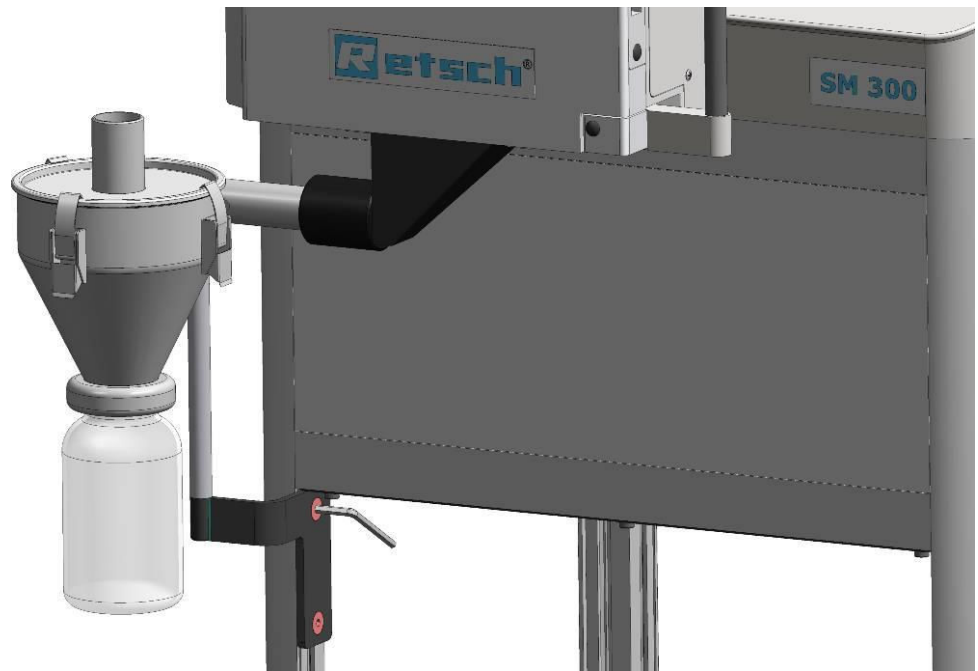

Fig. 23: Assembled cyclone

 **CAUTION**

Before using the industrial vacuum cleaning, read the operating instructions supplied with the vacuum cleaner.

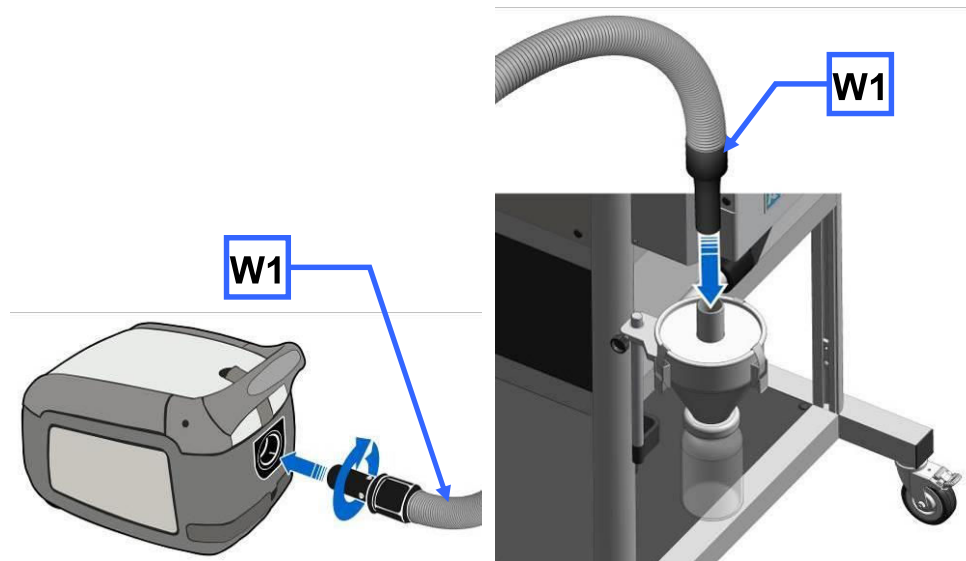

Fig. 24: Connecting the industrial vacuum cleaner

- Plug the connector for dust extraction (**W1**) into the top opening on the cyclone.



**7.1.1 Inserting the wide mouth bottle adapter**

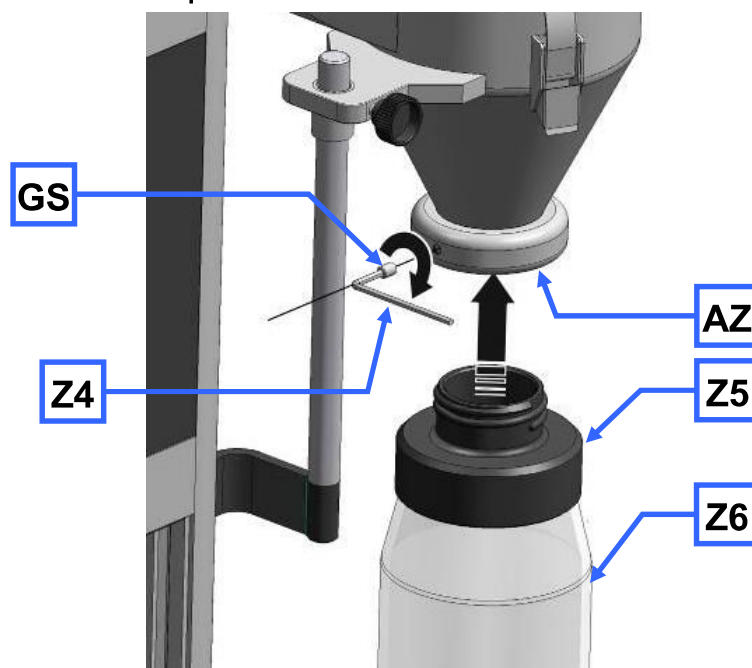

Fig. 25: Inserting the wide mouth bottle adapter

- Insert the adapter for wide mouth bottles (**Z5**) into the outlet opening of the cyclone (**AZ**).
- Affix the adapter using the threaded pin (**GS**).
- Use a SW3 Allen key to screw in the threaded pin (**Z4**).

This avoids the adapter turning when the wide mouth bottles are screwed in and out.

You can use 1l, 2l and 5l wide mouth bottles.

## 8 Cleaning and service

### 8.1 Adjusting the cutting bars

The cutting gap must be checked to ensure that the device is functioning satisfactorily (target distance 0.3mm). For this reason the cutting bars (**SL**) are arranged so that they can be shifted to permit adjustments to the cutting gap.

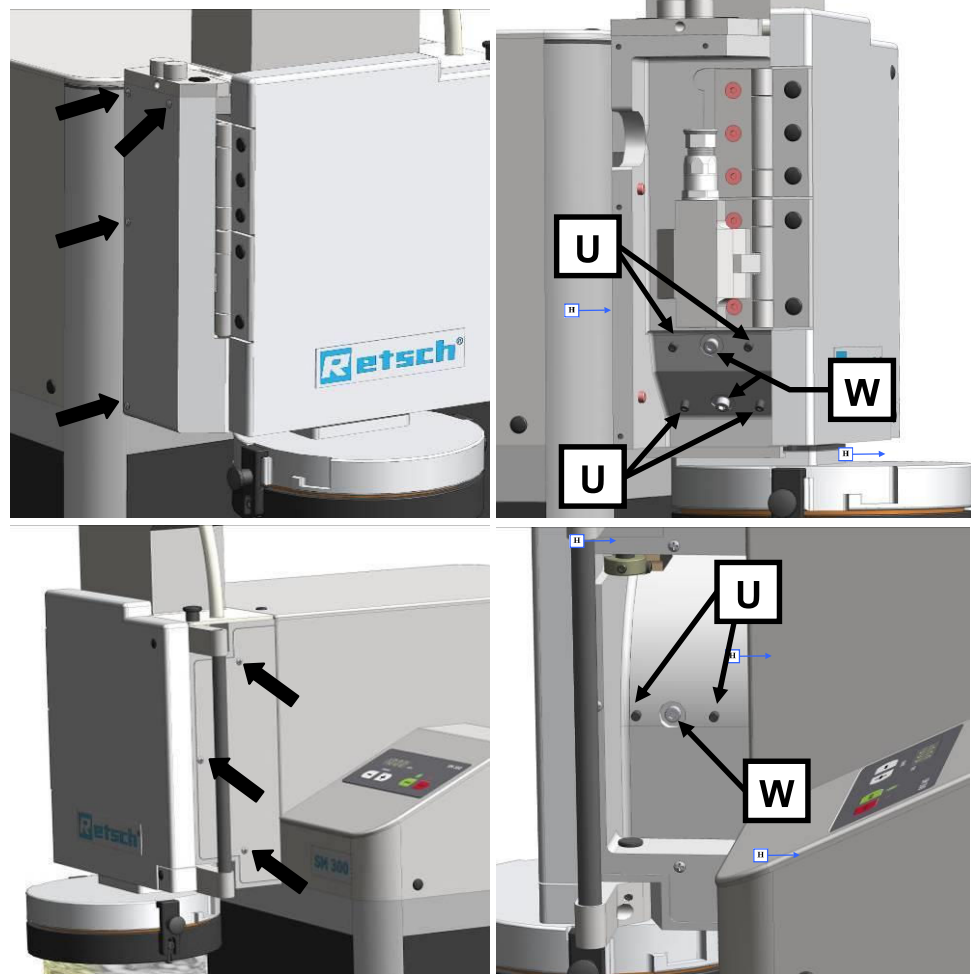

Fig. 6: Access to the cutting bars

- Unscrew the four screws on the left-hand cover.
- Unscrew the three screws on the right-hand cover.
- Open the grinding area door.
- Pull the rotor approx. 10 mm out of the grinding area until it can be freely rotated.

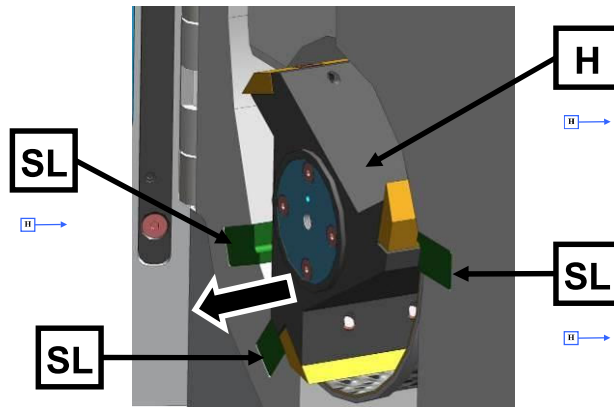

Fig. 7: Freely rotate the rotor

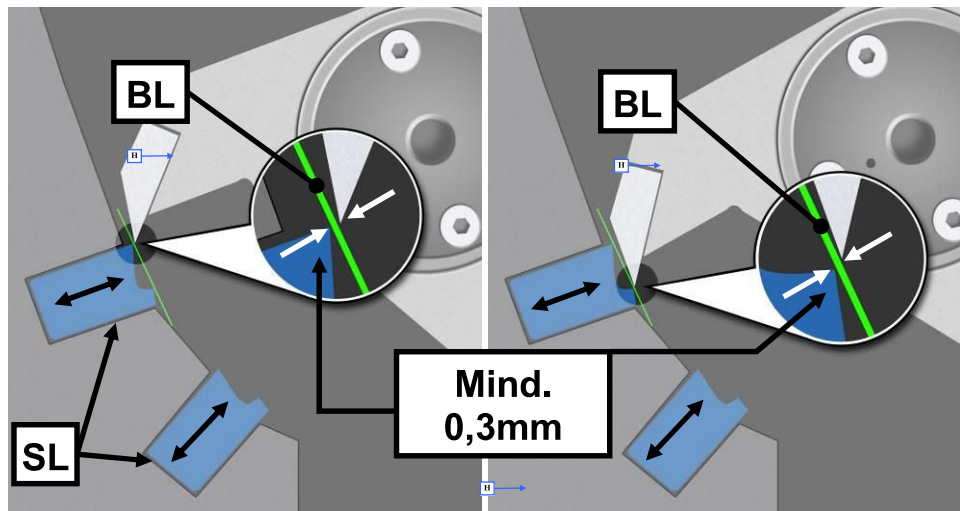

Fig. 8: Adjusting the cutting gaps

- Using a feeler gauge (**BL**) check the cutting gap for all three cutting bars (**SL**). It should be at least 0.3 mm.

The feeler gauge (**BL**) must be placed on both cut areas as shown in the diagram. The cutting gap must show a uniform distance across its entire depth. For this reason check the cutting gap across its entire depth.

The cutting edge that has the smallest distance to the knife denotes the cutting gap (**SP1/2**). The second cutting edge can have a larger cutting gap width.

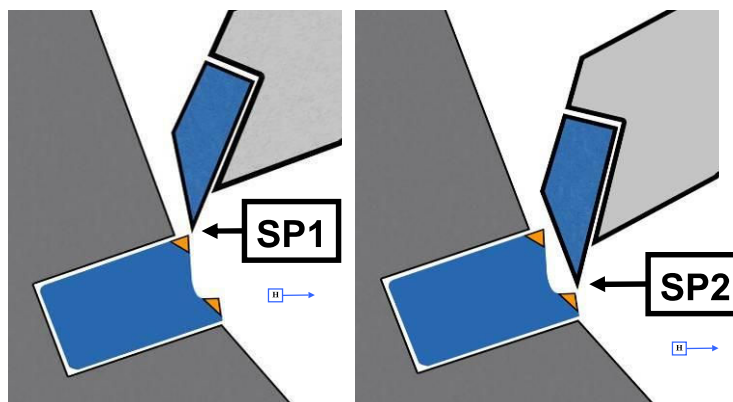

Fig. 26: Cutting gap

- By twisting the stud bolts (**U**) to the right, slide the cutting bar closer to the rotor blade and thereby reduce the cutting gap. Increase the cutting gap by twisting to the left.

- Tighten the screw (**WS**) and check the cutting gap. Repeat the process if necessary.
- After adjusting the cutting bar, tighten the screw (**W**) firmly again to 7Nm.
- Finally re-assemble the right and left-hand cover on the device.

*NB*

Do not set the cutting gap to less than 0.3 mm. Contact between the cutting plates and cutting bars can damage the mechanical components.

The tightening torque of the screw (**W**) must be 7Nm. This is necessary to guarantee that the cutting bars are securely positioned.

## 9 Fault messages

F.01	Overload	Frequency converter switched off because of overloading
F.04	Open the door	Close the door and close the lock.
F.04.-	Open the lock	Close the lock
F.11	Engine is overheated.	Starting impossible. Please wait until it cools down.
F.15	Fault in the safety circuit of the frequency converter activation	Door switch opened, Handle switch opened, The motor-driven lid lock monitoring has detected a fault.
F.18	Fault in the transformer's safety circuit	Contact monitoring   Relay   Inrush current limiter
F.26	Excessive temperature frequency converter	Frequency converter is overheated
F.37	No communication with the frequency converter	Frequency converter does not respond (4 seconds after start)

## 10 Disposal

Please observe the respective statutory requirements with respect to disposal. Information on disposal of electrical and electronic machines in the European Community.

Within the European Community the disposal of electrically operated devices is regulated by national provisions that are based on the EU Directive 2002/96/EC on Waste Electrical and Electronic Equipment (WEEE).

Accordingly, all machines supplied after 13.08.2005 in the business-to-business area to which this product is classified, may no longer be disposed of with municipal or household waste. To document this they have the following label:

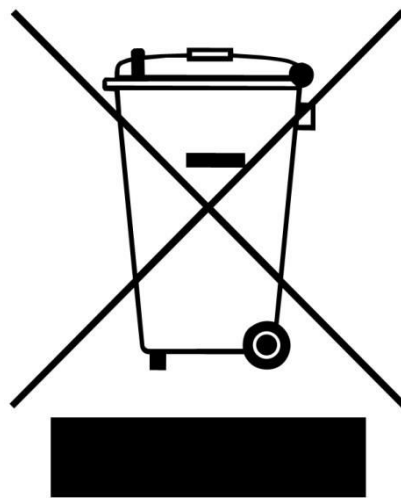

Fig. 27: Disposal label

Since the disposal regulations within the EU may differ from country to country we would request you to consult your supplier.

## 11 Index

### A

Access to the cutting bars 34  
Adjusting the cutting bars 34  
Adjusting the cutting gaps ng 35  
air exit 27  
air flow 27  
Ambient temperature 11  
Amperage 15  
Assembling and using the cyclone 29  
Atmospheric humidity 11

### B

Bar code 15  
Bayonet fixing 26

### C

Capacity 15, 18  
CE marking 15  
Changes 6  
Checking the cutting gap 25  
Cleaning and service 34  
Collecting Receptacle and Ring Sieve 27  
Conditions for the place of installation 11  
Confirmation 10  
Connecting the industrial vacuum cleaner 32  
Connection cable 15  
Copyright 6  
Cutting gap 25, 35  
Cyclone assembly 29

### D

Degree of protection 18  
Description 22  
Device designation 15  
Dimensions and weight 18  
Discharge flange 26  
Disposal 38  
Disposal label 15  
Disposal label 38

### E

Electrical connection 15  
Emissions 18  
Explanations of the safety warnings 7  
External fuse 15  
Eye bolt 12

### F

F.01 37  
F.04 37  
F.04.- 37  
F.11 37  
F.15 37  
F.18 37  
F.26 37

F.37 37

Fastening the cyclone support 31  
Fastening the discharge flange 30  
Fault messages 37  
Filling hole 28  
Freely rotate the rotor 25, 35  
Front View 19  
Front view from the left (detail) 20  
Function 22  
Fuse strength 15  
Fuse type 15

### G

General safety instructions 8

### I

Inserting the bottom sieve 24  
Inserting the filter unit and collecting receptacle 26  
Inserting the Rotor 26  
Inserting the sliding block 30  
Inserting the wide mouth bottle adapter 33  
Installation height 14  
Installation of the machine 14  
Installing the cyclone 31  
IP20 18

### M

Mains frequency 15  
Manufacturer's address 15  
Maximum relative humidity 11  
Mode of Operation of Feed Hopper 28  
Moderate or mild injury 7  
Motor rotation speed 18  
Motor speed 18  
Mounting and Removing the Ring Sieve 26  
Mounting the bottom sieve 23  
Mounting the Feed Hopper 12, 13

### N

Notes on the Operating Manual 6  
Number of fuses 15

### O

Opening and closing of the grinding chamber 23  
Opening the grinding chamber door. 23  
Operating elements and displays 21  
Operating the machine 19  
Overview table of the parts of the device 22

### P

Packaging 11  
Part number 15  
Plug 30  
Power version 15  
property damage 7  
Putting on the Protective Caps 14

**R**

Rated power 18  
Rear view 20  
Receptacle volume 18  
Regulations for the place of installation 15  
Removal grip 26  
Removing the discharge flange 29  
Removing the Rotor 25  
Removing the Transport Safeguard 12, 13  
Removing transport aid 12  
Removing Transport Safeguards 12  
Repairs 9  
Replacing the rotor 24  
Required floor space 18

**S**

Safety warnings 7  
Serial number 15  
serious injury 7  
Service Address 9  
Sliding block 30  
Starting the grinding process 27

Stopping the grinding process 27

**T**

Target group 8  
Technical data 17  
Temperature fluctuation and condensed water 11  
Transport 11  
Transport, scope of delivery, installation 11  
Turning the sliding block 31  
Type plate 15  
type plate description 15  
Type plate lettering 15

**U**

Use of the machine for the intended purpose 17

**V**

View of the control panel and the display 21  
Views of the Instrument 19

**Y**

Year of production 15



# LABORATORY CUTTING MILL

## SM300

**Certificate of CE-Conformity according to:**

**EC Mechanical Engineering Directive 2006/42/EC**

Applied harmonized standards, in particular:  
DIN EN ISO 12100                      Security of machines

**EC Directive Electromagnetic Compatibility 2004/108/EC**

Applied standards, in particular:  
DIN EN 55011                      B / Generic standard interference emission - living areas -  
DIN EN 61326-1                      Immunity

**Additional applied standards, in particular**

DIN EN 61010                      Safety prescriptions concerning measuring-, operating-, controlling- and  
laboratory equipment

**Authorized person for the compilation of technical documents:**

J. Bunke (technical documentation)

**The following records are held by Retsch GmbH in the form of Technical Documentation:**

Detailed records of engineering development, construction plans, study (analysis) of the measures required for conformity assurance, analysis of the residual risks involved and operating instructions in due form according to the approved regulations for preparation of user information data.

The CE-conformity of the Retsch laboratory cutting mill SM300 is assured herewith.

**In case of a modification to the machine not previously agreed with us as well as the use of not licensed spare parts and accessories this certificate will lose its validity.**

Retsch GmbH

Haan, January 2010

Dr. Stefan Mähler  
Manager technical services







# **Retsch**

Distributed by:

**Lab Unlimited**  
CARL STUART GROUP

Tallaght Business Park  
Whitestown, Dublin 24,  
Ireland  
D24 RFK3

Tel: (01) 4523432  
Fax: (01) 4523967  
E-mail: [info@labunlimited.com](mailto:info@labunlimited.com)  
Web: [www.labunlimited.com](http://www.labunlimited.com)

Quatro House, Frimley Road,  
Camberley,  
United Kingdom  
GU16 7ER

Tel: 08452 30 40 30  
Fax: 08452 30 50 30  
E-mail: [info@labunlimited.co.uk](mailto:info@labunlimited.co.uk)  
Web: [www.labunlimited.co.uk](http://www.labunlimited.co.uk)